

Technical Information

Fusion - GHSS 60"H Heated Self-Service Case

Structural Concepts®

DELIVERING FRESH. ALWAYS.™

DIMENSIONS / SHIPPING				
Model	L"	L1"	L2"	Est Wt (lbs)
GHSS460H	48.750	51.000	0.000	800
GHSS460H-4	48.750	51.000	0.000	N/A
GHSS660H	73.125	75.375	0.000	1,100

ELECTRICAL															
Model	System Circuit Volts			Ph	Frq	Rated Load Amps	Min Cir Amps	Max OCP Amps	Watts	Wires	NEMA Plug	Amps Lights	Amps Fans	Amps Anti-Sweats	Amps Misc/Refrig/Heat
GHSS460H	Heat (N/A)	Circuit #1	240	1	50-60	25.65	40	40	6,166	2+G	Leads Single	0.36	N/A	N/A	25.29
	Heat (N/A)	Circuit #1	208	3	50-60	17.13	30	30	4,655	3+G	Leads Single	0.36	N/A	N/A	21.93
	Heat (N/A)	Circuit #1	240	3	50-60	19.70	30	30	6,166	3+G	Leads Single	0.36	N/A	N/A	25.29
	Heat (N/A)	Circuit #1	240	1	50-60	27.45	40	40	5,752	2+G	Leads Single	0.36	N/A	N/A	27.09
GHSS460H-4	Heat (N/A)	Circuit #1	240	1	50-60	31.60	40	40	7,618	2+G	Leads Single	0.36	N/A	N/A	31.24
	Heat (N/A)	Circuit #1	208	3	50-60	27.45	40	40	5,752	3+G	Leads Single	0.36	N/A	N/A	27.09
	Heat (N/A)	Circuit #1	240	3	50-60	31.60	40	40	7,618	3+G	Leads Single	0.36	N/A	N/A	31.24
	Heat (N/A)	Circuit #1	240	1	50-60	32.06	50	50	6,589	2+G	Leads Single	1.10	N/A	N/A	30.96
GHSS660H	Heat (N/A)	Circuit #1	240	1	50-60	36.78	50	50	8,721	2+G	Leads Single	1.10	N/A	N/A	35.68
	Heat (N/A)	Circuit #1	208	3	50-60	27.38	40	40	6,589	3+G	Leads Single	1.10	N/A	N/A	30.96
	Heat (N/A)	Circuit #1	240	3	50-60	31.56	40	40	8,721	3+G	Leads Single	1.10	N/A	N/A	35.68
	Heat (N/A)	Circuit #1	240	1	50-60	31.56	40	40	8,721	3+G	Leads Single	1.10	N/A	N/A	35.68

REFRIGERATION														
Model	Zone	Section	System	Envt	REMOTE REFRIGERATION					GLYCOL / R744 REFRIGERATION				
					SST (°F)	Conv. Rack BTUH	Para. Rack BTUH	Defrost Interval (Hrs)	Defrost Duration	Total GPM	Pressure Drop (psi)	Concent (%)	Liquid Temp (°F)	

INTENDED ENVIRONMENT		
Type I - Designed to operate in ambient conditions of 75°F with 55% relative humidity unless noted otherwise under Envt above.		
WARMEST AVERAGE PRODUCT TEMP & INTENDED USE OF ZONES		
Zone	Temp (°F)	Intended Use
1	160	Packaged heated product

IMPORTANT NOTES
1) ELECTRICAL NOTE: If GFCI is required, a GFCI breaker MUST be used in lieu of a GFCI receptacle
2) 34" minimum door entry clearance required (without shipping skid).
3) The additional shelf option significantly increases electrical load for model. Refer to the -4 suffix model for these specifications.

REGULATORY	
All Models	ETL Listed to UL 197 ETL Listed to CAN/CSA 22.2 No. 109 ETL Sanitation to NSF/ANSI 4



Technical Information

Fusion - GHSS 60"H Heated Self-Service Case

Structural Concepts®

DELIVERING FRESH. ALWAYS.™

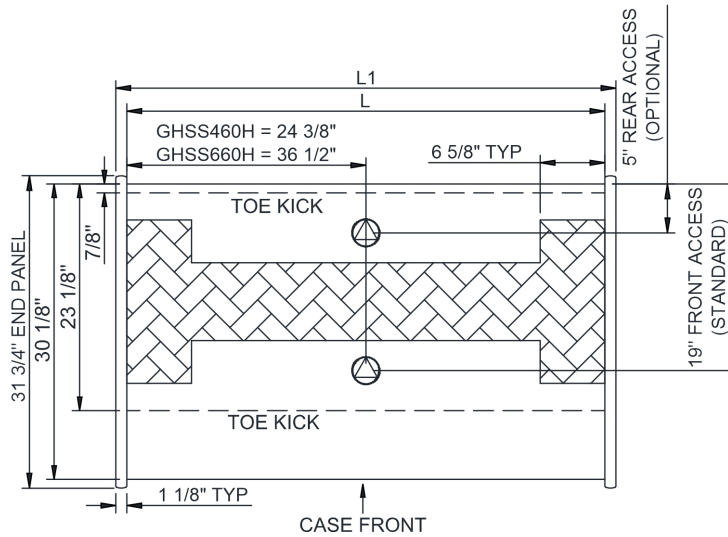
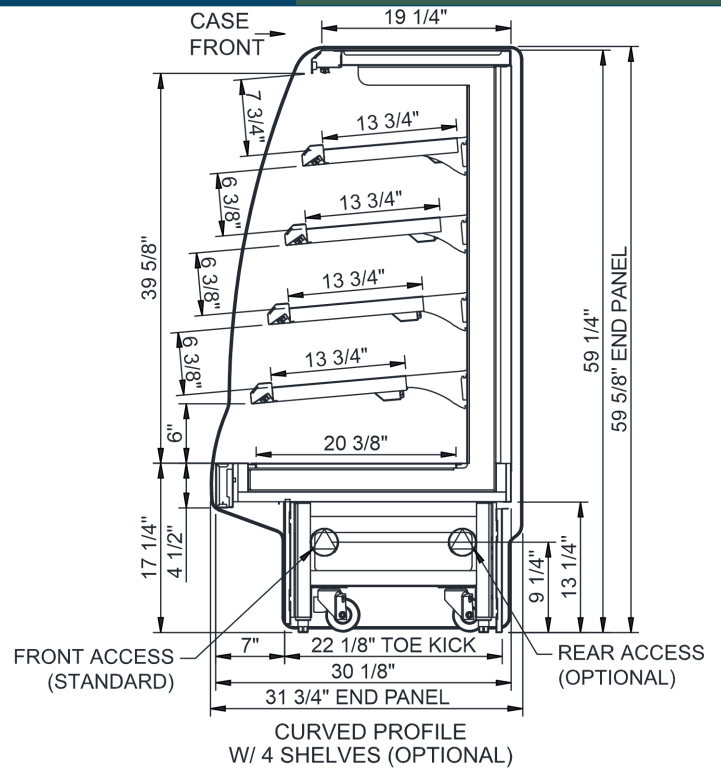
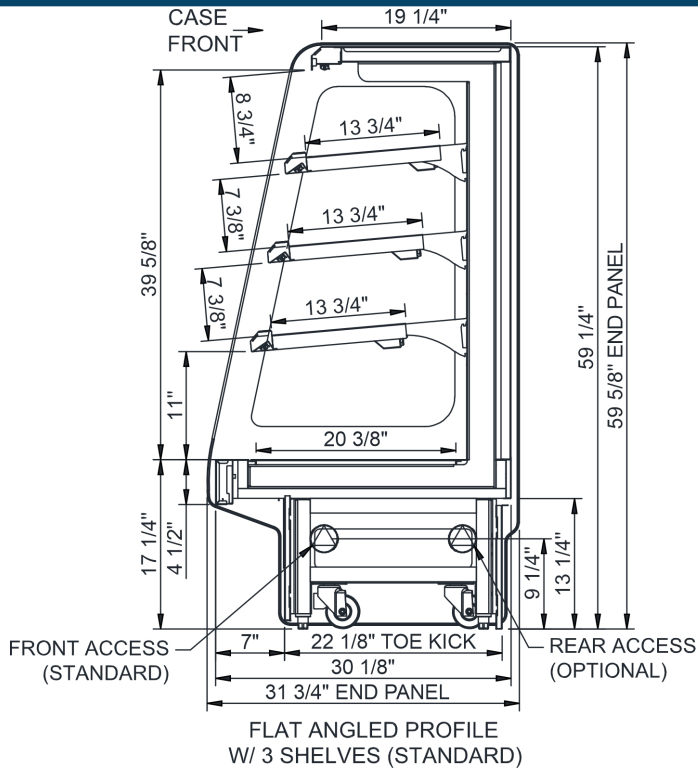

NOTE: ALL DIMENSIONS APPROXIMATE

⊗ ELECTRICAL JUNCTION BOX
(SUPPLIED WITH 6" LEADS OR POWER CORD).
⊙ LOCATION OF DRAIN TUBE FOR REMOTE REF.
ONLY (SUPPLIED WITH 3/4" OR 1 1/2" PVC TUBE).

⊕ REFRIGERATION LINE CONNECTION.
⊞ REMOTE FLOOR SINK & UTILITIES
ACCESS AREA.

▨ SELF-CONTAINED CASE SERVICE ACCESS AREA.
▩ DRY CASE SERVICE ACCESS AREA.