

OASIS[®] USER MANUAL 21-33895

Important!
See Counter
Installation Guide
Section In This
Manual Before
Proceeding With
Installation!

SELF-SERVICE REFRIGERATED MERCHANDISERS

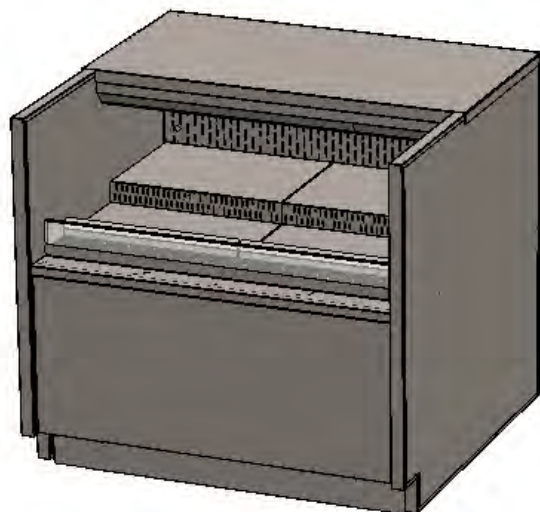
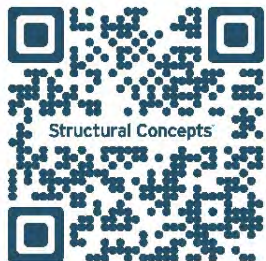

Model C33R

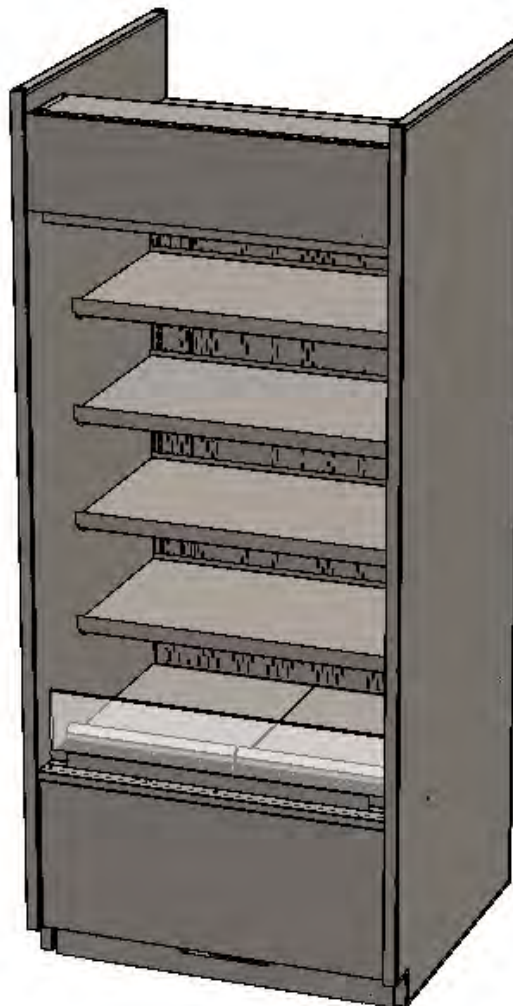

Model B37R

Models Represented In This Operating Manual*

C33R, C43R, C53R, CN33R, CN43R, CN53R, B37R, B47R, B57R, B67R, BN37R, BN47R, BN47R.8128, BN47R.8128A, BN57R, B35R, B45R, B55R, B65R

* This Manual May Also Be Applicable To Models Not Listed Herein.

Structural Concepts[®]

DELIVERING FRESH. ALWAYS.™

Structural Concepts Corp. · 888 E. Porter Rd · Muskegon, MI 49441 Phone: 231.798.8888 Fax: 231.798.4960 · www.structuralconcepts.com

TABLE OF CONTENTS

TABLE OF CONTENTS	2
OVERVIEW / TYPE / COMPLIANCE / WARNINGS / PRECAUTIONS / WIRING / PLUGS	3-5
SHIPPING BRACKET REMOVAL / TOE-KICK REMOVAL / REMOVAL FROM SKID / CASE ALIGNMENT	6
SHIMMING FRAME SUPPORT RAILS / ADJUSTING LEVELERS	7
LOAD LEVEL & TEMPERATURE GUIDE	8-9
SHELF AND DECK LOAD LIMITS.....	10
START-UP AND OPERATION: THERMOSTAT / MAIN POWER SWITCH / LIGHTS SWITCH / FILTER	11
REFRIGERATION - REAR CONDENSATE PACKAGE ACCESS (NO SCREW REMOVAL REQUIRED)	12
REFRIGERATION - FRONT CONDENSATE PACKAGE ACCESS (NO SCREW REMOVAL REQUIRED)	13
REFRIGERATION - CONDENSATE PACKAGE ILLUSTRATED PARTS BREAKDOWN	14
GENERAL CLEANING (TO BE PERFORMED BY STORE PERSONNEL)	15
PREVENTIVE MAINTENANCE (TO BE PERFORMED BY TRAINED SERVICE PROVIDERS ONLY)	16-22
TROUBLESHOOTING (TO BE PERFORMED BY STORE PERSONNEL)	23-24
SERIAL LABEL & LOCATION / TECHNICAL INFORMATION / ADD'L INFORMATION	25
PROGRAMMABLE CONTROLLER INFORMATION.....	26
SCC TECHNICAL SERVICE CONTACT INFORMATION / LIMITED WARRANTY	27

Models Represented In This Operating Manual*

C33R, C43R, C53R, CN33R, CN43R, CN53R, B37R, B47R, B57R, B67R, BN37R, BN47R, BN47R.8128, BN47R.8128A, BN57R, B35R, B45R, B55R, B65R

*** This Manual May Also Be Applicable To Models Not Listed Herein.**

OVERVIEW

- These Structural Concepts merchandisers are designed to merchandise packaged products at 41°F (5°C) or less product temperatures.
- Refrigerated Display cases are classified by “test Room Climate Class.” Test Room Climate Class 8 is to be operated in a environment of 24°C (75.2°F) 55% R.H.
- Cases should be installed and operated according to this operating manual’s instructions to ensure proper performance. Improper use will void warranty.
- Component parts shall be replaced with like components.

NSF/ANSI TYPE II ENVIRONMENTAL CONDITIONS

- This unit is designed for the display of products in ambient indoor store conditions where temperature and humidity are maintained within a specific range.
- NSF/ANSI Type II Conditions: Product is displayed in store conditions with maximum ambient temperature of 80 °F (27 °C) and maximum relative humidity of 55%.

COMPLIANCE

- Performance issues when in violation of applicable NEC, federal, state and local electrical and plumbing codes are not covered by warranty. See below.

WARNINGS/DANGER

- This sheet contains important warnings to prevent injury or death. Please read carefully!

REFRIGERANT DISCLOSURE STATEMENT

- This equipment is prohibited from use in California with any refrigerants on the “List of Prohibited Substances” for that specific end-use, in accordance with California Code of Regulations, title 17, section 95374.
- This disclosure statement has been reviewed and approved by Structural Concepts and Structural Concepts attests, under penalty of perjury, that these statements are true & accurate.



COMPLIANCE
 This equipment **MUST** be installed in compliance with all applicable NEC, federal, state and local electrical and plumbing codes.



WARNING
 Risk of electric shock. Disconnect power before servicing unit.
CAUTION! More than one source of electrical supply is employed with units that have separate circuits.
Disconnect ALL ELECTRICAL SOURCES before servicing.



WARNING: This product can expose you to chemicals, including Urethane (Ethyl Carbamate), which are known to the state of California to cause cancer and birth defects or other reproductive harm. For more information go to P65Warnings.ca.gov.



WARNING: Hazardous moving parts. Do not operate unit with covers removed. Fan blades may be exposed when deck panel is removed. Disconnect power before removing deck panel.



WARNING
 Condensate Pan is Hot!
 Disconnect and allow to cool before cleaning or removing from case.



DANGER
 Risk of fire or explosion. Flammable refrigerant is used in this case. Consult repair manual/owner’s guide before servicing this product. To minimize risk of possible ignition due to incorrect parts or improper service, this case is **ONLY** to be serviced by factory authorized service personnel. The flammable refrigerant type specified on case nameplate is on serial label.

OVERVIEW, CONT'D

- This sheet details dangers due to flammable refrigerant. It addresses operational area required, case placement guidelines, child-proofing the unit and refrigerant recycling and/or disposal, etc.
- Appliance is to be installed in accordance with the Safety Standard for Refrigeration Systems, ANSI/ASHRAE15.

DANGER

- Please read section shown below for specifics on risk of fire explosion, service guidelines, LFL, etc.

CAUTION

- This sheet also details the area required for operation, areas to avoid placing case, guidelines for children (and others with limited capabilities) while near box door cases.
- This sheet also provides information on refrigeration recovery, recycling and disposal.

>> See next page for continuation.



DANGER

- Refrigeration unit contains gas under high pressure. Do not tamper with or puncture the system. Contact qualified service personnel before disposal.
- Risk of fire or explosion. Flammable refrigerant is used in this case.
- Consult repair manual/owner's guide before servicing this product.
- Do not store explosive substances (such as aerosol cans with a flammable propellant) in this case.
- Do not use an electrical appliance INSIDE the food storage compartments unless its type is recommended by manufacturer.
- To minimize risk of ignition due to incorrect parts or improper service, this case is ONLY to be serviced by factory authorized service personnel.
- Flammable refrigerant type specified on case nameplate is on serial label.
- Contains a charge of 150g of R290 refrigerant with a lower flammability limit (LFL) of .038kg/m³

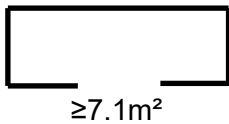

CAUTION

Minimum room floor area required for operation of these cases is ≥7.1m².

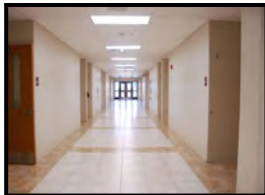

CAUTION

- These cases are NOT to be installed in lobbies or locations of egress, such as hallways, public corridors.
- If case is placed in an enclosure or surrounding structure, keep all of the case's ventilation openings clear of obstructions.



CAUTION

- This unit is not intended for use by persons (including children) with reduced physical, sensory or mental capabilities, or lack of experience and knowledge, unless they have been given supervision or instruction concerning use of the unit by a person responsible for their safety.
- Children should be supervised to ensure that they do not 'play with' the unit.



CAUTION: REFRIGERANT RECOVERY/RECYCLING/DISPOSAL

- When recycling or discarding case, refrigerants MUST BE handled according to local, state and federal codes, requirements and regulations.
- If disposing of a refrigerated case that uses ozone depleting chemicals in its refrigeration system, make sure the refrigerant is removed by a qualified service technician and properly disposed of.
- If you intentionally release refrigerant into the atmosphere, you may be subject to fines or other penalties (under regulations mandated by environmental regulators and/or legislative edict).

PRECAUTIONS

- This sheet contains important precautions to prevent damage to unit or merchandise. Please read carefully!
- See previous page for specifics on **OVERVIEW**, **TYPE**, **COMPLIANCE** and **WARNINGS**.
- Do not use mechanical devices or other means to accelerate the defrosting process, other than those recommended by the manufacturer
- Only factory OEM replacement parts may be used on appliances using flammable refrigerants.
- Risk of electric shock. If the SUPPLY CORD is damaged, it must be replaced by the manufacturer, its service agent or similarly qualified persons with factory OEM replacement parts only.

WIRING DIAGRAM FORMAT & LOCATION

- Each case has its own wiring diagram folded and in its own packet.
- Wiring diagram may be near ballast box, field wiring box, raceway cover, or other related location.



CAUTION! LAMP REPLACEMENT GUIDELINES
LED lamps reflect specific size, shape and design.
Any replacements must meet factory specifications, resist breakage and reflect similar appearance as lamps from factory.



CAUTION! CHECK CONDENSATE PAN, POSITION & CONNECTIONS!
Water on flooring can cause extensive damage!

- Before powering up case, check that condensate pan is positioned directly under case's condensate drain.
- Also, check that there are **NO LOOSE CONNECTIONS**, including overflow condensate pan and its power cord plug (if part of the condensate package).



CAUTION! DO NOT RELY ON THERMOMETERS OR THERMOSTATS FOR PRODUCT (FOOD) TEMPERATURES.

- Thermometers & thermostats reflect air temperatures **ONLY**.
- For **ACTUAL** product (food) temperatures, use a calibrated food probe thermometers **ONLY**.
- For accurate readings, **DO NOT** use infrared food thermometers.

WARNING

Do not use means to accelerate the defrosting process or to clean, other than those recommended by the manufacturer.

The appliance shall be stored in a room without continuously operating ignition sources (for example: open flames, an operating gas appliance or an operating electric heater.)

Do not pierce or burn.

Be aware that refrigerants may not contain an odor.

CASE REMOVAL FROM SKID (LOCKING/UNLOCKING CASTERS)

1. Removing Case Shipping Brackets That Are Attached To Skid

- Remove screws holding shipping brackets to skid.
- Remove shipping brackets from skid.
- See illustrations below. *Note: Shipping Brackets will vary in size, shape, material and location depending upon case type and model.*

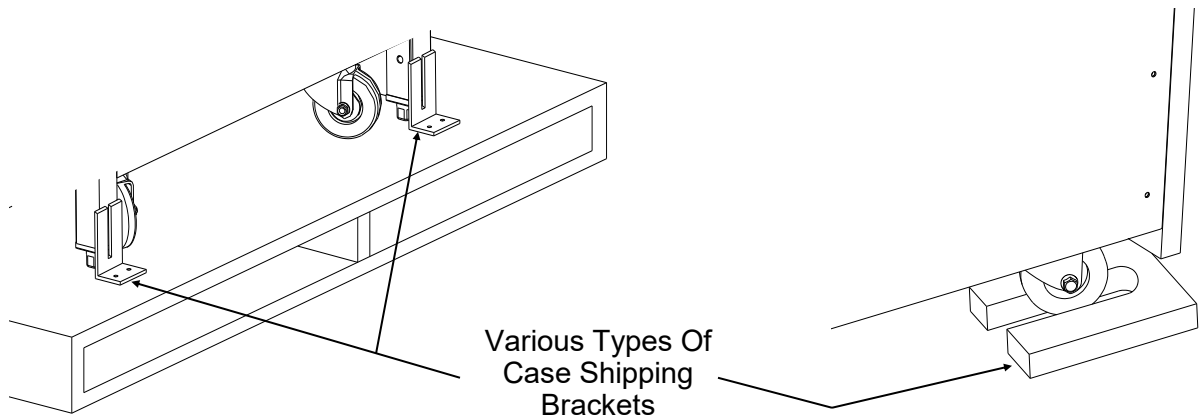

2. Remove Case (With Casters) From Skid

- A. Place ramp up against skid (to allow case to smoothly slide off from skid).
- B. Maintain support of case at all times or center of gravity may cause case to fall.
- C. Unlock Casters. Slide unit to rear of skid. Slide down ramp and off from skid.

Note: See next page for panel attachment instructions. CN33R shown for reference only, you model may differ in appearance.

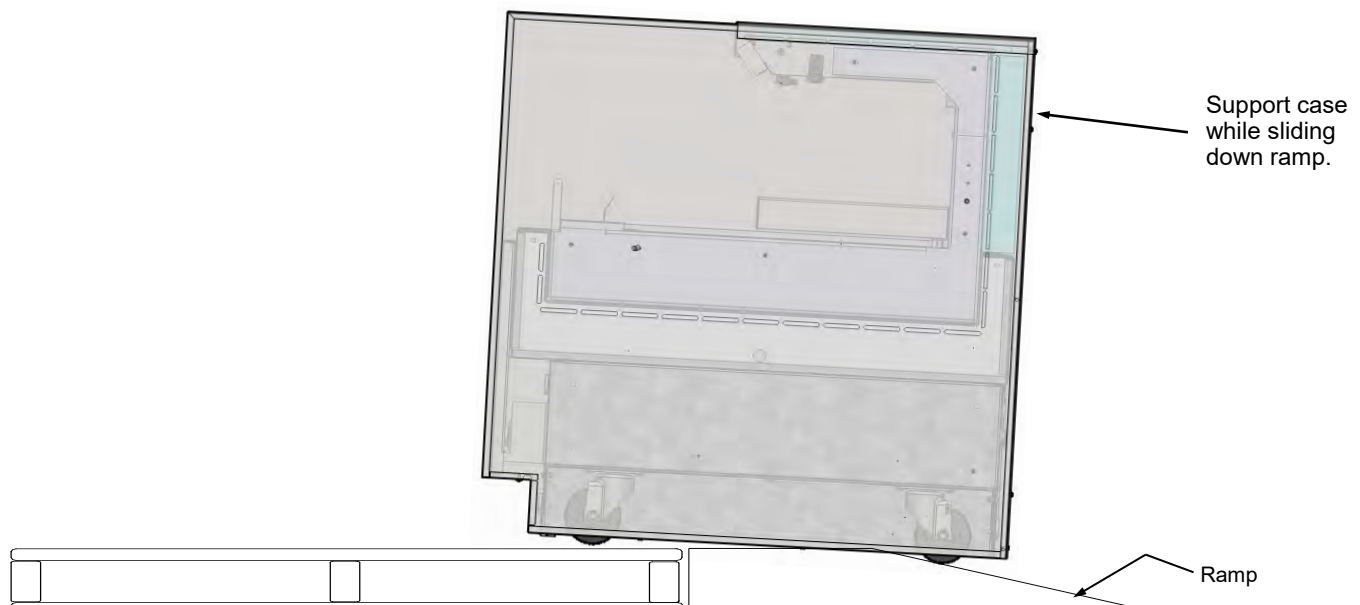

SHIMMING FRAME SUPPORT RAILS / ADJUSTING LEVELERS

1. Cases With Levelers: Adjust

- **Important!** For cases with casters, after case is in proper position, levelers must then be **LOWERED** to floor.
- Adjust case so it is level and plumb.
- You may need to remove front and/or rear toe-kick to access levelers.
- Use adjustable wrench (and possibly a pry bar) to adjust leveler.
- Do not use pry bar on toe-kick (it may buckle).
- Do not use pry bar on end panel (it may chip).
- Use pry bar **ONLY** on base frame to avoid damaging case.
- Use a block to reach base frames with pry bar.
- See below illustrations.

2. Sealing Cases

- If the case is installed and intended to be stationary, a generous bead of food grade silicone sealant along the bottom of the front toe-kick and rear panel is needed.
- When properly applied, this food grade silicone sealant will prevent water from seeping to the floor as well as crumbs and other residue from entering beneath the case.

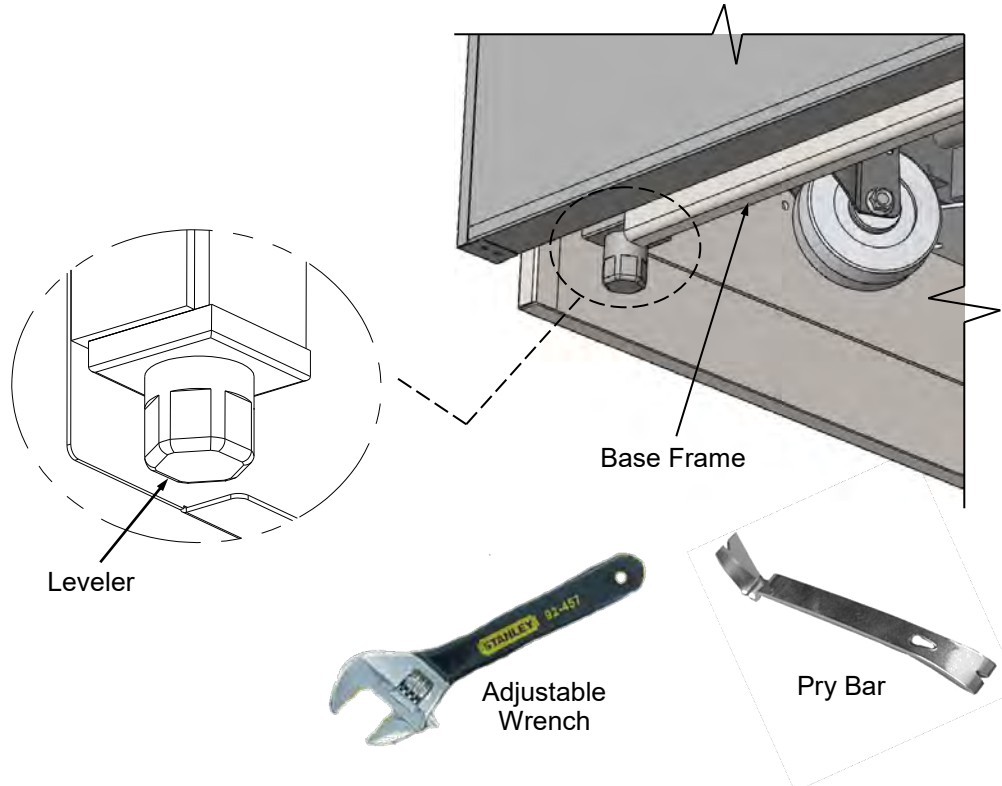

LOAD LEVEL GUIDE & TEMPERATURE GUIDE - MODELS C(T)(L)(H)R

LOAD LEVEL & TEMPERATURE GUIDE - MODELS C(T)(L)(H)R

>> FOLLOW THESE PRODUCT PLACEMENT GUIDELINES TO MAINTAIN DESIRED PRODUCT TEMPERATURES.
>> FRONT TO REAR PRODUCT TEMPS ARE ESTIMATES ONLY.
>> NOTES CORRESPOND WITH ILLUSTRATIONS SHOWN.
1. ALLOW AT LEAST 1" SPACE BETWEEN PRODUCT AND ITS SHELF ABOVE.

2. AT CASE REAR, ALLOW AT LEAST 1" SPACE BETWEEN PRODUCT AND REAR PERFORATED PLENUM.
3. DO NOT BLOCK 1 1/4" AIR RETURN OPENING WITH PRODUCT.
>> IF YOU ARE UNABLE TO MAINTAIN DESIRED PRODUCT TEMPERATURES, SEE TROUBLESHOOTING SECTION IN MANUAL.

PACKAGED
PRODUCT
ILLUSTRATION

PRODUCT
TEMPERATURE
RANGE SHOWN
AT RIGHT.

37 °F TO 41 °F
PRODUCT AT
CASE FRONT

33 °F To 37 °F
PRODUCT AT
CASE REAR

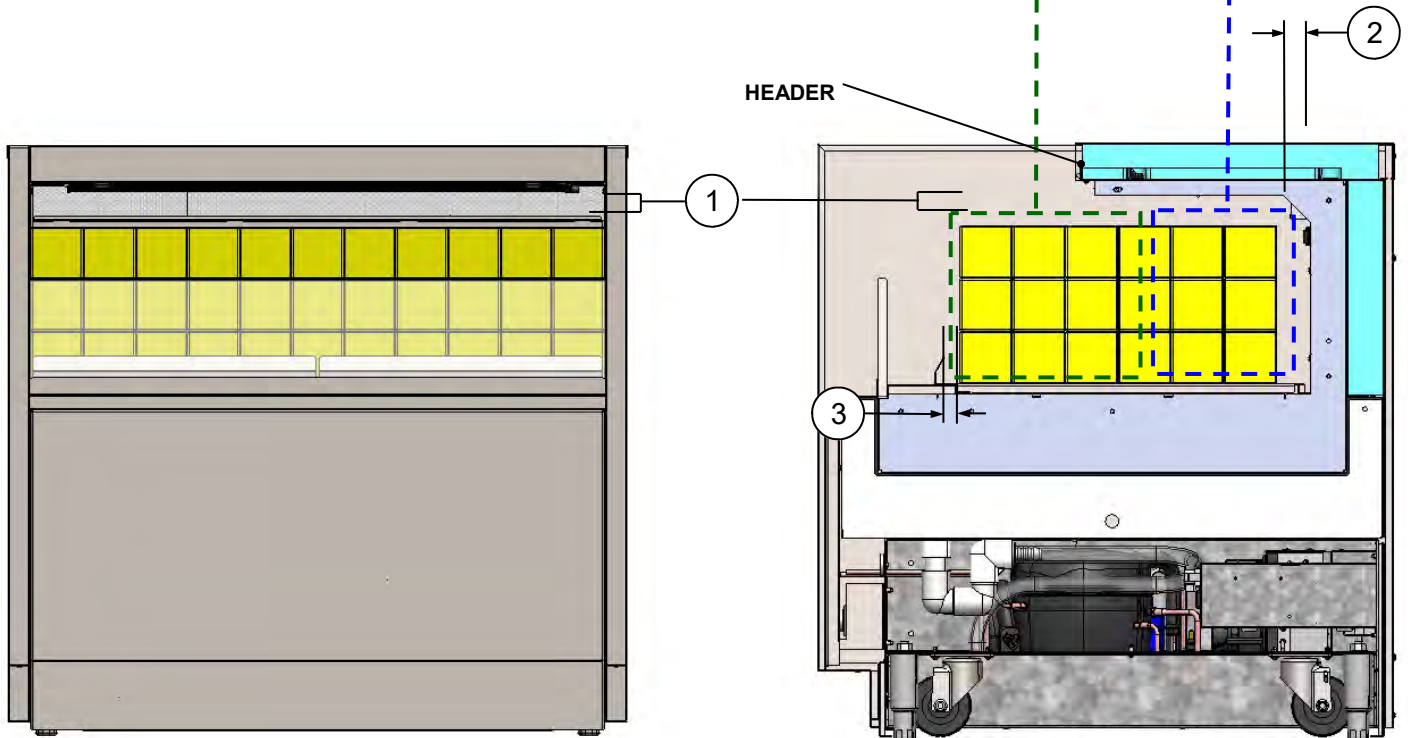

MODEL C33R SHOWN ABOVE. CASE IS PARTIALLY DISASSEMBLED, CROSS SECTIONED AND PACKAGED PRODUCT LADEN FOR ILLUSTRATIVE PURPOSES ONLY.

LOAD LEVEL GUIDE & TEMPERATURE GUIDE - MODEL B(T)(L)(H)R

LOAD LEVEL & TEMPERATURE GUIDE - MODEL B(T)(L)(H)R

>> FOLLOW THESE PRODUCT PLACEMENT GUIDELINES TO MAINTAIN DESIRED PRODUCT TEMPERATURES.

>> FRONT TO REAR PRODUCT TEMPS ARE ESTIMATES ONLY.

>> NOTES CORRESPOND WITH ILLUSTRATIONS SHOWN.

1. AT TOP SHELF, KEEP PRODUCT BELOW THERMOMETER (THAT IS ATTACHED TO REAR PERFORATED PLENUM).

2. ALLOW AT LEAST 1" SPACE BETWEEN PRODUCT AND ITS SHELF ABOVE.

3. AT CASE REAR, ALLOW AT LEAST 1" SPACE BETWEEN PRODUCT AND REAR PERFORATED PLENUM.

4. DO NOT BLOCK 1 1/4" AIR RETURN OPENING WITH PRODUCT.

>> IF YOU ARE UNABLE TO MAINTAIN DESIRED PRODUCT TEMPERATURES, SEE TROUBLESHOOTING SECTION IN MANUAL.

PRODUCT TEMPERATURE RANGE SHOWN AT RIGHT.

37 °F TO 41 °F
PRODUCT AT CASE FRONT

33 °F To 37 °F
PRODUCT AT CASE REAR

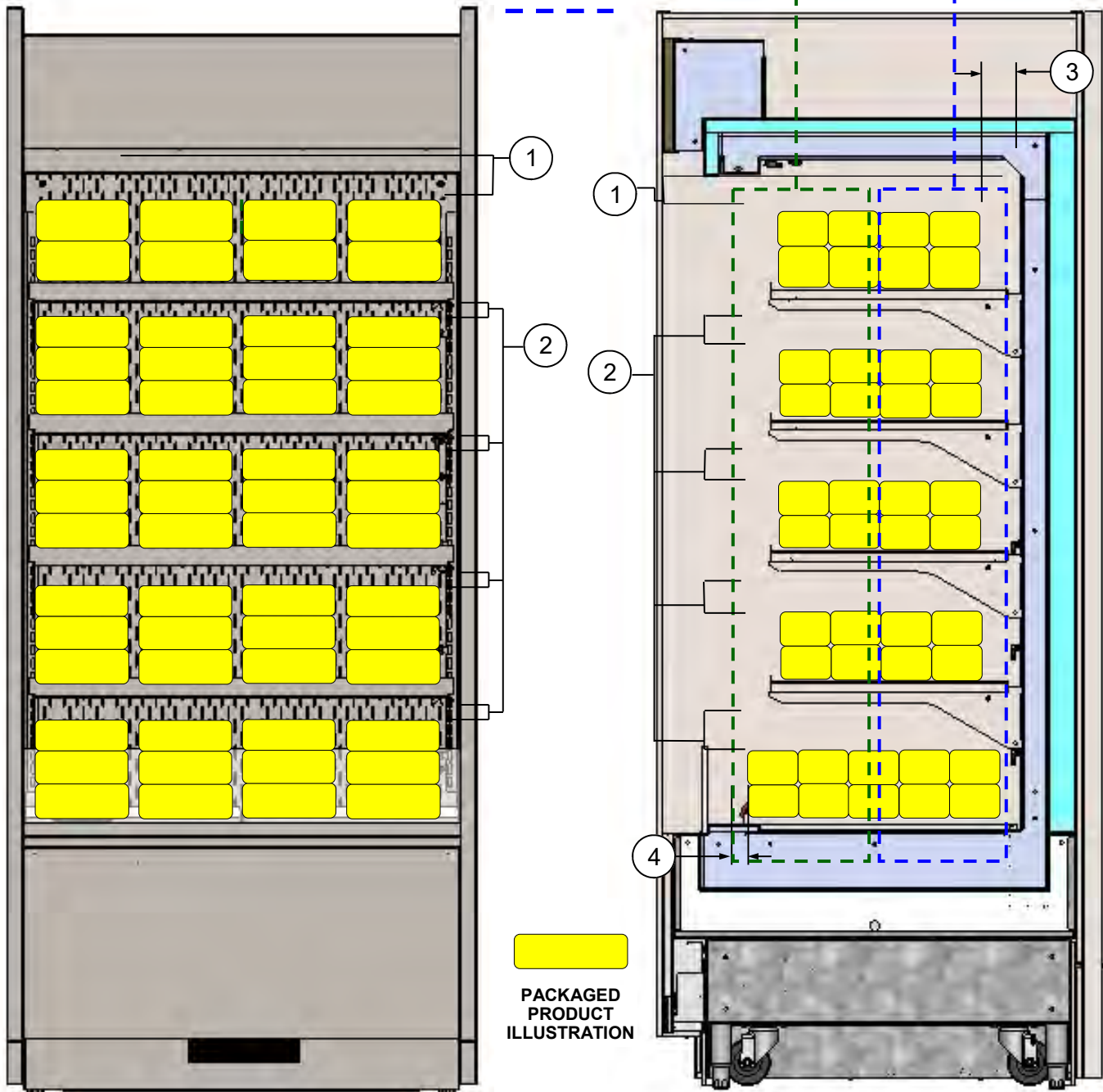

MODEL B37R SHOWN ABOVE. CASE IS PARTIALLY DISASSEMBLED, CROSS-SECTIONED

SHELF AND DECK LOAD LIMITS

The chart below are the load limits for the shelves and decks. All weights below are for a uniform distributed load.

Model	Max Shelf Load (lbs)	Max Deck Pan Load (lbs)
B33R	N/A	66
B43R	N/A	92
B53R	N/A	106
B63R	N/A	132
B35R	110	66
B45R	154	92.4
B55R	198	105.6
B65R	231	132
BN37R	66	33
BN47R	92.4	46.2
BN57R	118.8	52.8
B37R	110	66
B47R	154	92.4
B57R	198	105.6
B67R	231	132
B37D	110	66
B47D	154	92.4

1. Merchandiser Start-Up

- Do not use an extension cord with this appliance.
 - Do not operate this equipment with a damaged cord, plug or outlet.
 - Ensure that the main power switch is off.
 - Plug cord into a certified 110V electrical outlet with ground.
 - Turn main power switch on (see location at rear of case in illustration below)
 - Coil fans should turn on.
 - From inside of the case, check for discharge air from front baffle, to confirm that the fans are functioning properly.
 - When the case is in a start-up mode or has been idle for a long period of time, unit may require 75 minutes running time to pull-down temperature.
 - Turn lights on.
 - Light switch is located on the ceiling of merchandising area.
 - The lights should come on at the same time.
 - Always maintain front and rear airflow clearance of twelve inches.
- Obstruction or restriction of air can void warranty.
 - **Note:** Case temperature setting is determined by case size. Temperature is controlled by a thermostat. If a temperature setting change is required, refer to instructions in **PROGRAMMABLE CONTROLLER** sections of this manual.

Note: Illustration Shown Reflects **REAR ACCESS** Condenser Package. Optional **FRONT ACCESS** Condenser Package Has Similar Electrical Layout.

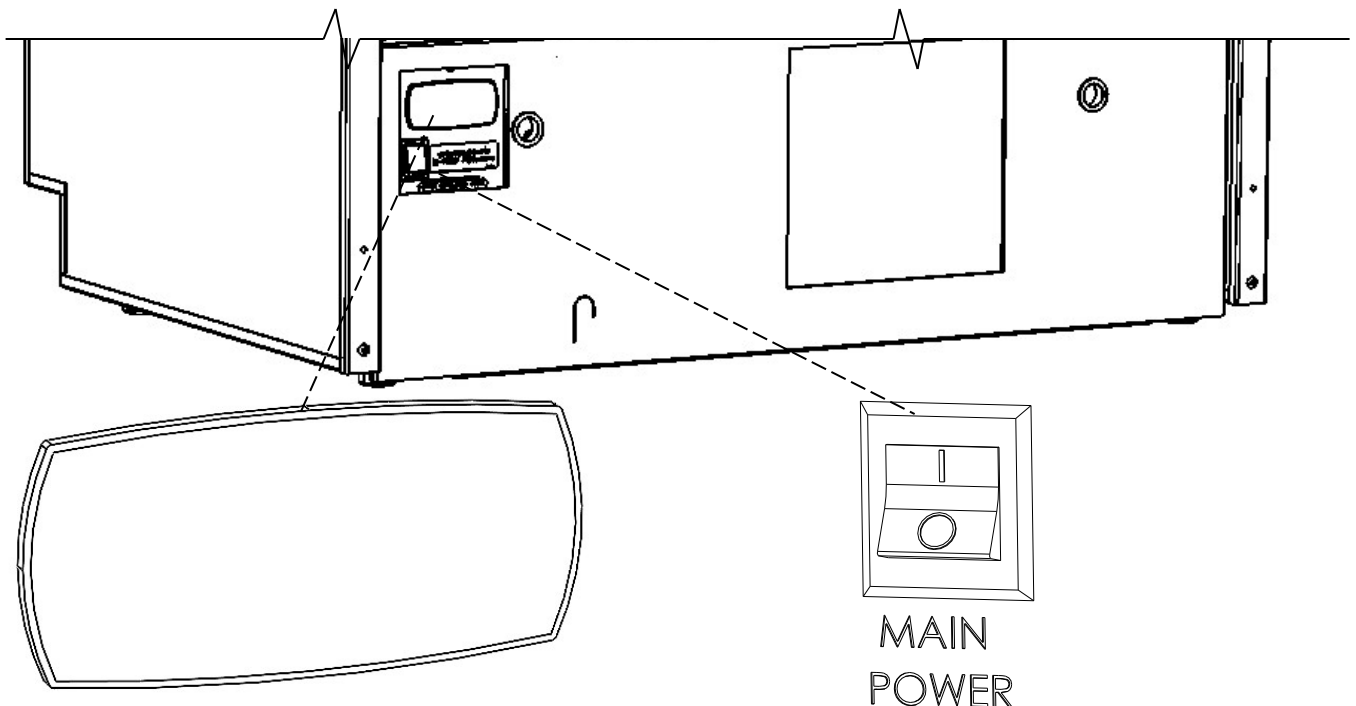

REFRIGERATION - REAR CONDENSATE PACKAGE ACCESS (NO SCREW REMOVAL REQUIRED)

Refrigeration Fundamentals, Continued

1. Rear Condensate Package Access - No Screw Removal Required

- **Assembly or disassembly and servicing of condensate package is to be accomplished by a licensed refrigeration contractor.**
- Remove rear grille by grasping two (2) finger holes and pulling outward.

- Rear grille will then be free from rear panel magnets.

Note: CN33R shown for reference only, you model may differ in appearance.

Rear Panel Magnet

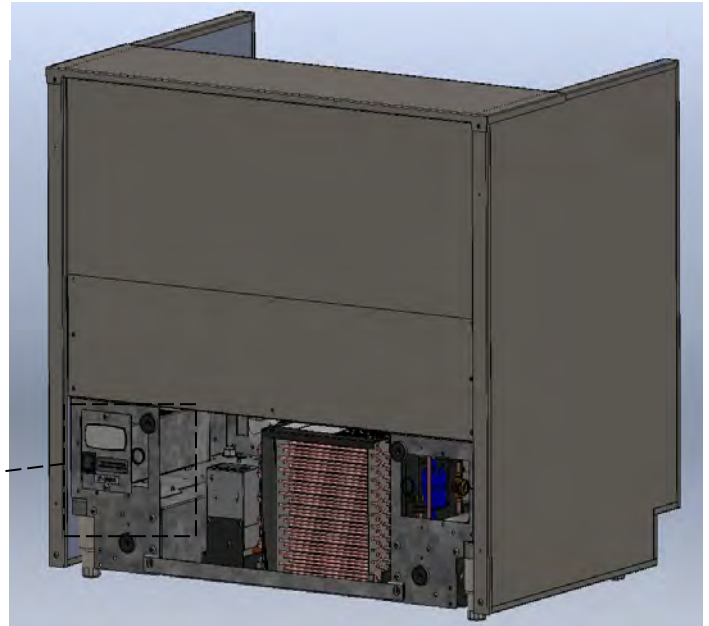

Model CN33R Disassembly

Finger Holes

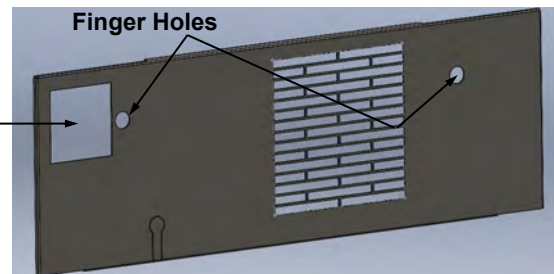

Controller Access

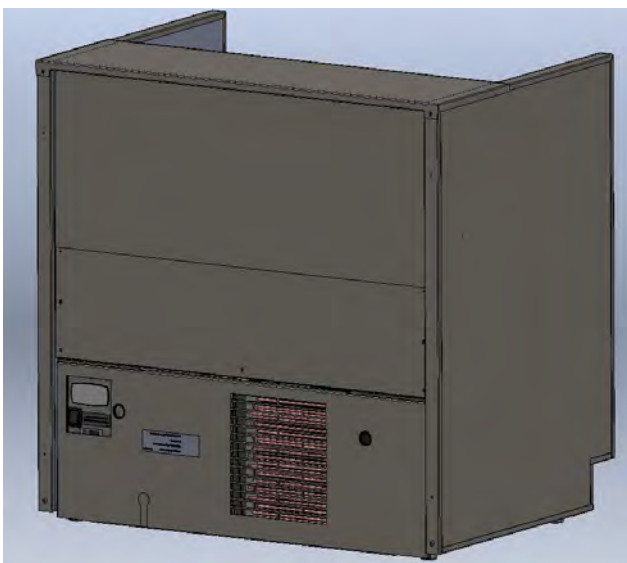

Model CN33R Fully Assembled

REFRIGERATION - FRONT CONDENSATE PACKAGE ACCESS (NO SCREW REMOVAL REQUIRED)

Refrigeration Fundamentals, Continued

2. Front Condensate Package Access - No Screw Removal Required

- ***Assembly or disassembly and servicing of condensate package is to be accomplished by a licensed refrigeration contractor.***
1. View of fully attached front panel and toe-kick.
 2. Remove front panel by grabbing the bottom of the panel and pull forward to release magnets. Slide down to disengage the security tabs.
 3. Remove the toe-kick from the magnets to access the compressor package.

4. Carefully slide condenser package pan out from under case to access various components.
>> Return all components to case in reverse order they were removed.

Note: CN33R shown for reference only, you model may differ in appearance.

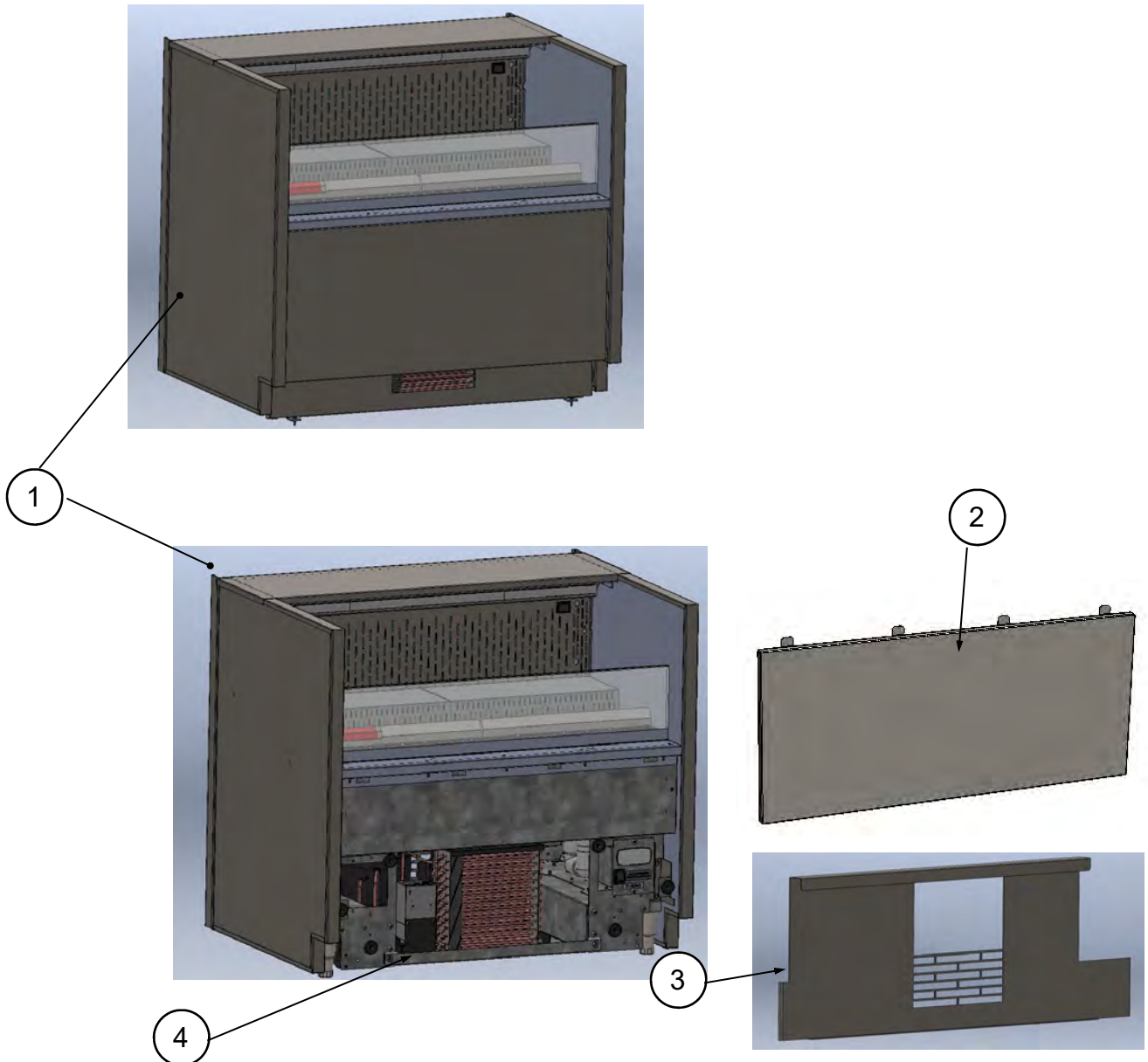

Refrigeration Fundamentals, Continued

3. Condensate Package Illustrated Parts Breakdown

- **Assembly or disassembly and servicing to be accomplished by licensed refrigeration contractor.**
- After rear grille has been removed, slide condensate package out slowly and carefully.

Note: CN33R shown for reference only, you model may differ in appearance.

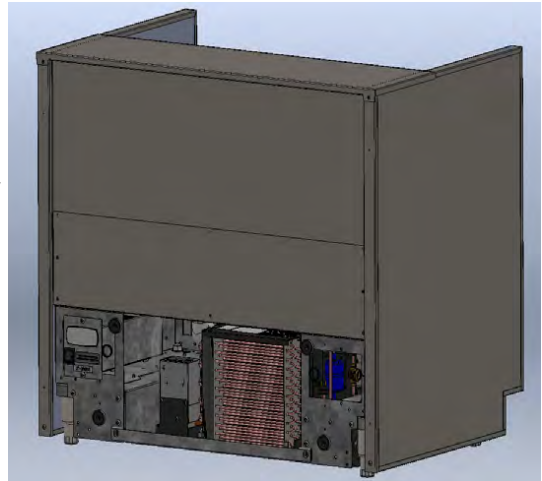

Rear Grille

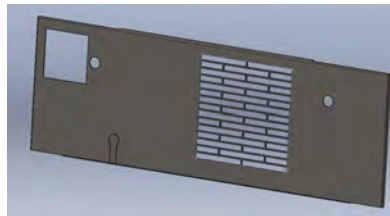

Note: Condensate Package Is Shown Rotated For Illustrative Purposes

Condensing Coil (and Internal Fan)

Filter Drier

Sight Glass

Condensate Overflow Pan

Compressor Electrical Box

Compressor

Hot Gas Loop Condensate Pan

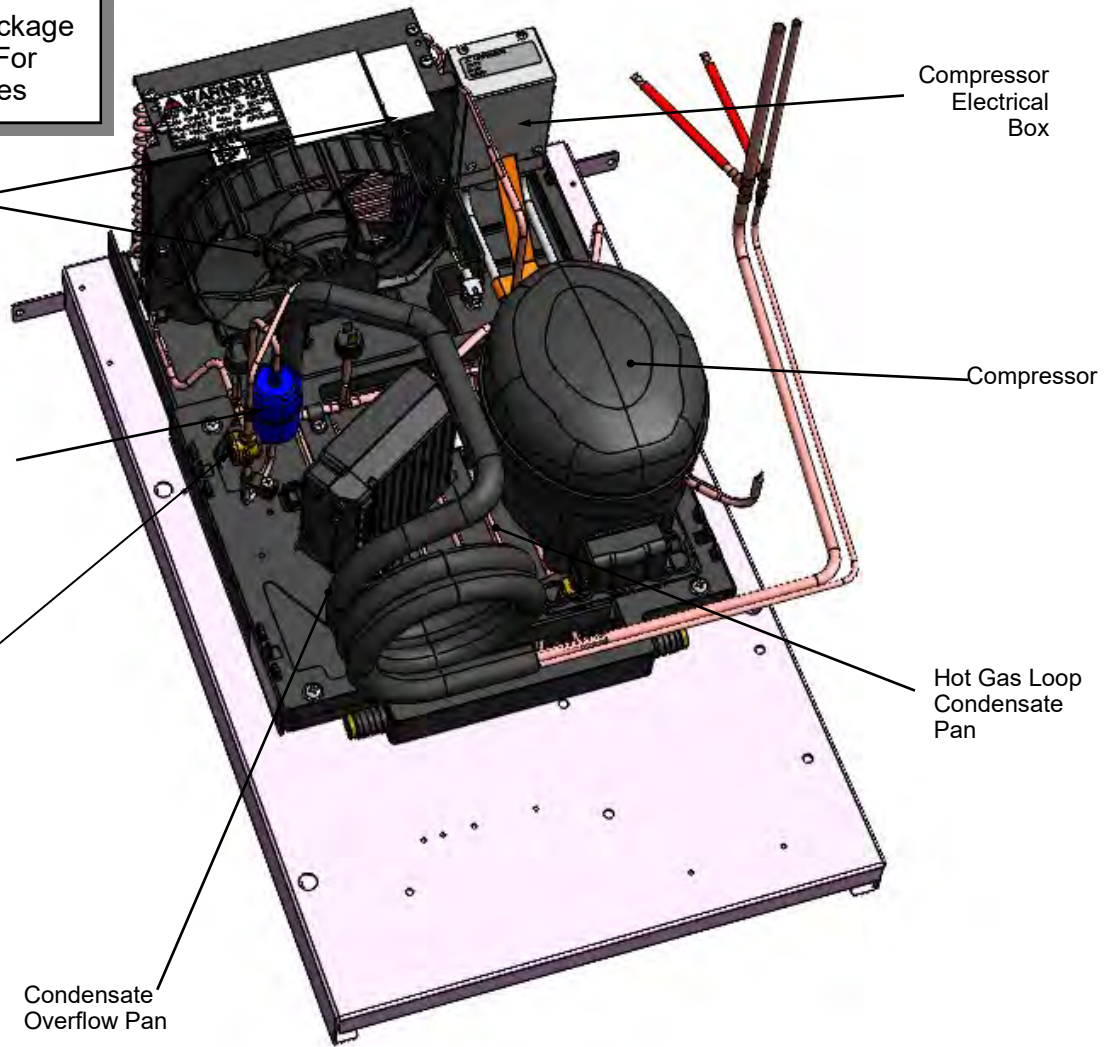

GENERAL CLEANING (TO BE PERFORMED BY STORE PERSONNEL)

FREQ.	INSTRUCTIONS
Daily	<u>Sides/Top/Front Panel:</u> Clean with mild all-purpose cleaner and soft cloth.
Daily	<u>Acrylic Air Deflector:</u> <ul style="list-style-type: none"> • Clean with mild all-purpose cleaner and soft cloth. • Never use ammonia-based cleaners (nor household or commercial window cleaner) on acrylic.
Daily	<u>Decks, Air Return Grilles, Product Display Risers & Shelving (If Any):</u> <ul style="list-style-type: none"> • Clean with mild all-purpose cleaner and soft cloth. • For more thorough cleaning, remove from case rear (by lifting up and off). Submerge in warm soapy water and use a nylon brush to remove hardened residue. Rinse thoroughly. Dry with soft cloth. Return to case.
Weekly	<u>Rear Perforated Plenum:</u> <ul style="list-style-type: none"> • Clean with mild all-purpose cleaner and soft cloth.
Monthly	<u>Security Cover (Optional):</u> <ul style="list-style-type: none"> • Wipe down with mild all-purpose cleaner and soft cloth. • Dry with soft cloth. • Condenser coil without Clean Sweep Option <ul style="list-style-type: none"> • Use a rag or soft-bristle brush to remove dust particles from coil fins • As needed, vacuum dust particles from the coil to prevent them from collecting. • Also, refer to the instructions on page 21.
Quarterly	<u>Under Case Cleaning:</u> Quarterly (or whenever condenser package is removed from under case, vacuum (or broom) under case to remove dust, debris and dirt that may collect. <ul style="list-style-type: none"> • Condenser coil with Clean Sweep Option <ul style="list-style-type: none"> • Use a rag or soft-bristle brush to remove dust particles from coil fins • As needed, vacuum dust particles from the coil to prevent them from collecting. • Also, refer to the instructions on page 21.
Quarterly	<u>Evaporator Coil and Tub:</u> <ul style="list-style-type: none"> • Turn off the main power and unplug the case. • Remove evaporator fan panel and clean tub, coil, and drain with warm water and mild soap solution. Remove any debris that may clog drain. • Plug the case back in and turn on the main power.

WARNING! TURN OFF CASE BEFORE PERFORMING PREVENTIVE MAINTENANCE!

Maintenance and Service Notes

- All maintenance staff and others working in the local area shall be instructed on the nature of work being carried out. Work in confined spaces shall be avoided.
- The area shall be checked with an appropriate refrigerant detector prior to and during work, to ensure the technician is aware of potentially toxic or flammable atmospheres. Ensure that the leak detection equipment being used is suitable for use with all applicable refrigerants, i.e., nonsparking, adequately sealed, or intrinsically safe.
- If any hot work is to be conducted on the refrigerating equipment or any associated parts, appropriate fire extinguishing equipment shall be available on hand. A dry chemical or CO₂ fire extinguisher should be adjacent to the charging area.
- No person carrying out work in relation to a refrigerating system which involves exposing any pipe work shall use any sources of ignition in such a manner that it may lead to the risk of fire or explosion. All possible ignition sources, including cigarette smoking should be kept sufficiently far away from the site of installation, repairing, removing and disposal, during which refrigerant can possibly be released to the surround space. Prior to work taking place, the area around the equipment shall be surveyed to make sure that there are no flammable hazards or ignition risks. "No Smoking" signs shall be displayed.
- Ensure that the area is in the open or that it is adequately ventilated before breaking into the system or conducting any hot work. A degree of ventilation shall continue during the period that the work is carried out. The ventilation should safely disperse any released refrigerant and preferably expel it externally into the atmosphere.

Checks to the refrigerating equipment

- Where electrical components are being changed, they shall be fit for the purpose and to the correct specification. At all times, the manufacturer's maintenance and service guidelines shall be followed. If in doubt, consult the manufacturer's technical department for assistance.
- The following check shall be applied to installation using FLAMMABLE REFRIGERANTS:
 - a) the actual REFRIGERANT CHARGE is in accordance with the room size within which the refrigerant containing parts are installed;
 - b) the ventilation machinery and outlets are operating adequately and are not obstructed;
 - c) if an indirect refrigeration circuit is being used, the secondary circuit shall be checked for the presence of refrigerant;
 - d) marking to the equipment continues to be visible and legible. Markings and signs that are illegible shall be corrected;
 - e) refrigerating pipe or components are installed in a position where they are unlikely to be exposed to any substance which may corrode refrigerant containing components, unless the components are constructed of materials which are inherently resistant to being corroded or are suitably protected against being so corroded.

Checks to electrical devices

- Repair and maintenance to electrical components shall include initial safety checks and component inspection procedures. If a fault exists that could compromise safety, then no electrical supply shall be connected to the circuit until it is satisfactorily dealt with. If the fault cannot be corrected immediately but it is necessary to continue operation, an adequate temporary solution shall be used. This shall be reported to the owner of the equipment, so all parties are advised.
- Initial safety checks shall include:
 - a) that capacitors are discharged: this shall be done in a safe manner to avoid possibility of sparking;
 - b) that no live electrical components and wiring are exposed while charging, recovering or purging the system;
 - c) that there is continuity of earth bonding.

WARNING! TURN OFF CASE BEFORE PERFORMING PREVENTIVE MAINTENANCE!

Maintenance and Service Notes

Repairs to sealed components

- During repairs to sealed components, all electrical supplies shall be disconnected from the equipment being worked upon prior to any removal of sealed covers, etc. If it is absolutely necessary to have an electrical supply to equipment during servicing, then a permanent opening form of leak detection shall be located at the most critical point to warn of a potentially hazardous situation.
- Particular attention shall be paid to the following to ensure that by working on electrical components, the casing is not altered in such a way that the level of protection is affected. This shall include damage to cables, excessive number and connections, terminals not made to original specification, damage to seals, incorrect fitting of glands, etc.
- Ensure that the apparatus is mounted securely.
- Ensure that seals or sealing materials have not degraded to the point that they no longer serve the purpose of preventing the ingress of flammable atmospheres. Replacement parts shall be in accordance with the manufacturer's specifications.

Repair to intrinsically safe components

- Do not apply any permanent inductive or capacitance loads to the circuit without ensuring that this will not exceed the permissible voltage and current permitted for the equipment in use.
- Intrinsically safe components are the only types that can be worked on while live in the presence of a flammable atmosphere. The test apparatus shall be at the correct rating.
- Replace components only with parts specified by the manufacturer. Other parts can result in the ignition of refrigerant in the atmosphere from a leak.
- NOTE The use of silicon sealant can inhibit the effectiveness of some types of leak detection equipment. Intrinsically safe components do not have to be isolated prior to working on them.

Cabling

- Check that cabling will not be subject to wear, corrosion, excessive pressure, vibration, sharp edges, or any other adverse environmental effects. The check shall also take into account the effects of aging or continual vibration from sources such as compressors or fans.

Detection of flammable refrigerants

- Under no circumstances shall potential sources of ignition be used in the searching for or detection of refrigerant leaks. A halide torch (or any other detector using a naked flame) shall not be used.
- The following lead detection methods are deemed acceptable for all refrigerant systems.
- Electronic leak detectors may be used to detect refrigerant leaks but, in the case of FLAMMABLE REFRIGERANTS the sensitivity might not be adequate, or might need recalibration. (Detection equipment shall be calibrated in a refrigerant-free area.) Ensure that the detector is not a potential source of ignition and is suitable for the refrigerant used. Leak detection equipment shall be set at a percentage of the LFL of the refrigerant and shall be calibrated to the refrigerant employed, and the appropriate percentage of gas (25% maximum) is confirmed.
- Leak detection fluids are also suitable for use with most refrigerants but the use of detergents containing chlorine shall be avoided as the chlorine can react with the refrigerant and corrode the copper pipe-work.
- NOTE examples of leak detection fluids are
 - bubble method.
 - fluorescent method agents.
- If a leak is suspected, all naked flames shall be removed/extinguished.
- If a leakage of refrigerant is found which requires brazing, all of the refrigerant shall be recovered from the system, or isolated (by means of shut off valves) in a part of the system remote from the leak. Removal of refrigerant shall be according to the removal and evacuation procedures below.

WARNING! TURN OFF CASE BEFORE PERFORMING PREVENTIVE MAINTENANCE!

Maintenance and Service Notes

Removal and evacuation

- When breaking into the refrigerant circuit to make repairs-or for any other purpose-conventional procedures shall be used. However, for flammable refrigerants it is important that the best practice be followed, since flammability is a consideration. The following procedure shall be adhered to:
 - a) safely remove refrigerant following local and national regulations;
 - b) purge the circuit with inert gas;
 - c) evacuate (optional for A2L);
 - d) purge with inert gas (optional for A2L);
 - e) open the circuit by cutting or brazing.
- The refrigerant change shall be recovered into the correct recovery cylinders if venting is not allowed by local and national codes. For appliances containing flammable refrigerants, the system shall be purged with oxygen-free nitrogen to render the appliance safe for flammable refrigerants. This process might need to be repeated several times. Compressed air or oxygen shall not be used for purging refrigerant systems.
- For appliances containing flammable refrigerants, refrigerant purging shall be achieved by breaking the vacuum in the system with oxygen-free nitrogen and continuing to fill until the working pressure is achieved, then venting to atmosphere, and finally pulling down to a vacuum (optional for A2L). This process shall be repeated until no refrigerant is within the system (optional for A2L). When the final oxygen-free nitrogen change is used, the system shall be vented down to atmospheric pressure to enable work to take place.
- Ensure that the outlet for the vacuum pump is not close to any potential ignition sources and that ventilation is available.

Charging procedures

- In addition to conventional charging procedures, the following requirements shall be followed.
 - a) Ensure that contamination of different refrigerants does not occur when using charging equipment. Hoses or lines shall be as short as possible to minimize the amount of refrigerant contained in them.
 - b) Cylinders shall be kept in an appropriate position according to the instructions.
 - c) Ensure that the REFRIGERATING SYSTEM is earthed prior to charging the system with refrigerant.
 - d) Label the system when charging is complete (if not already).
 - e) Extreme care shall be taken not to overfill the REFRIGERATING SYSTEM.
- Prior to recharging the system. It shall be pressure-tested with the appropriate purging gas. The system shall be lead-tested on completion of charging but prior to commissioning. A follow up leak test shall be carried out prior to leaving the site.

WARNING! TURN OFF CASE BEFORE PERFORMING PREVENTIVE MAINTENANCE!

Maintenance and Service Notes

Decommissioning

- Before carrying out this procedure, it is essential that the technician is completely familiar with the equipment and all its detail. It is recommended good practice that all refrigerants are recovered safely. Prior to the task being carried out, an oil and refrigerant sample shall be taken in case analysis is required prior to re-use of recovered refrigerant. It is essential that electrical power is available before the task is commenced.
 - a) Become familiar with the equipment and its operation.
 - b) Isolate the system electrically.
 - c) Before attempting the procedure, ensure that:
 - i) mechanical handling equipment is available, if required, for handling refrigerant cylinders;
 - ii) all personal protective equipment is available and being used correctly;
 - iii) the recovery process is supervised at all times by a competent person;
 - iv) recovery equipment and cylinders conform to the appropriate standards.
 - d) Pump down refrigerant system, if possible.
 - e) If a vacuum is not possible, make a manifold so that refrigerant can be removed from various parts of the system.
 - f) Make sure that cylinder is situated on the scales before recovery takes place.
 - g) Start the recovery machine and operate in accordance with instructions.
 - h) Do not overfill cylinders (no more than 80% volume liquid charge).
 - i) Do not exceed the maximum working pressure of the cylinder, even temporarily
 - j) When the cylinders have been filled correctly and the process completed, make sure that the cylinders and the equipment are removed from the site properly and all isolation valves on the equipment are closed off.
 - k) Recovered refrigerant shall not be charged into another refrigerating system unless it has been cleaned and checked.
- Equipment shall be labelled stating that it has been de-commissioned and emptied of refrigerant. The label shall be dated and signed. For appliances containing flammable refrigerants, ensure that there are labels on the equipment stating the equipment contains flammable refrigerant.

WARNING! TURN OFF CASE BEFORE PERFORMING PREVENTIVE MAINTENANCE!

Maintenance and Service Notes

Recovery

- When removing refrigerant from a system, either for servicing or decommissioning, it is recommended good practice that all refrigerants are removed safely.
- When transferring refrigerant into cylinders, ensure that only appropriate refrigerant recovery cylinders are employed. Ensure that the correct number of cylinders for holding the total system charge is available. All cylinders to be used are designated for the recovered refrigerant and labeled for that refrigerant (i.e., special cylinders for the recovery of refrigerant). Cylinders shall be complete with pressure-relief valve and associated shut-off valve in good working order. Empty recovery cylinders are evacuated and, if possible, cooled before recovery occurs.
- The recovery equipment shall be in good working order with a set of instructions concerning the equipment that is at hand and shall be suitable for the recovery of all appropriate refrigerants including, when applicable, FLAMMABLE REFRIGERANTS. In addition, a set of calibrated weighing scales shall be available and in good working order. Hoses shall be complete with leak-free disconnect coupling and in good condition. Before using the recovery machine, check that it is in satisfactory working order, has been properly maintained and that any associated electrical components are sealed to prevent ignition in the event of refrigerant release. Consult manufacturer if in doubt.
- The recovered refrigerant shall be returned to the refrigerant supplier in the correct recovery cylinder, and the relevant waste transfer note arranged. Do not mix refrigerants in recovery units and especially not in cylinders.
- If compressors or compressor oils are to be removed, ensure that they have been evacuated to an acceptable level to make certain that FLAMMABLE REFRIGERANT does not remain within the lubricant. The evacuation process shall be carried out prior to returning the compressor to the suppliers. Only electric heating to the compressor body shall be employed to accelerate this process. When oil is drained from a system, it shall be carried out safely.

WARNING! TURN OFF CASE BEFORE PERFORMING PREVENTIVE MAINTENANCE!

QUARTERLY PREVENTIVE MAINTENANCE INSTRUCTIONS

Condensate Package (Including Overflow Condensate Pan):

Caution! You must turn main power switch off before cleaning!

- Remove front (or rear) grille (by removing thumbscrews or disconnecting from magnets).
- Carefully slide out refrigeration assembly (taking care to not damage coil)!
- Remove wicking material (if any).
- Use vacuum (in suction mode) and brush to dislodge and remove dust both in and on coil fins.
- To remove dust/debris from inner fins, place damp rags around condensing fan motor brackets (to collect airborne dust). Then, switch vacuum to blow mode to blow air through condenser coils and into damp rags on fans. Blow entire surface of condensing coil to assure that all entrenched dust is removed. Caution! Coil fins are sharp!
- Use a scrub-brush and a non-corrosive de-scaling solution (to remove calcium, lime and rust) from condensate pan. Clean hot gas loop (for EnergyWise units) or electric coil (for standard units). Follow instructions as to proper dilution, safety precautions and scrubbing method.
- After thoroughly cleaning pan with scrub-brush and solution, rinse component with clean water and wipe dry with sponge or paper towel.
- Use mild all-purpose cleaner and soft cloth to clean fans, sight glass, overflow pan, etc.
- Return wicking material to mounting brackets. If wicking material is tattered, torn or disintegrating, replace with new. If wicking material is not available, contact Structural Concepts. See toll-free number at last page of operating manual.
- Slide condenser package back under case.
- Return front (or rear) grille to case.
- Turn power back on to case.

Note: Condensate Package Is Shown Rotated For Illustrative Purposes

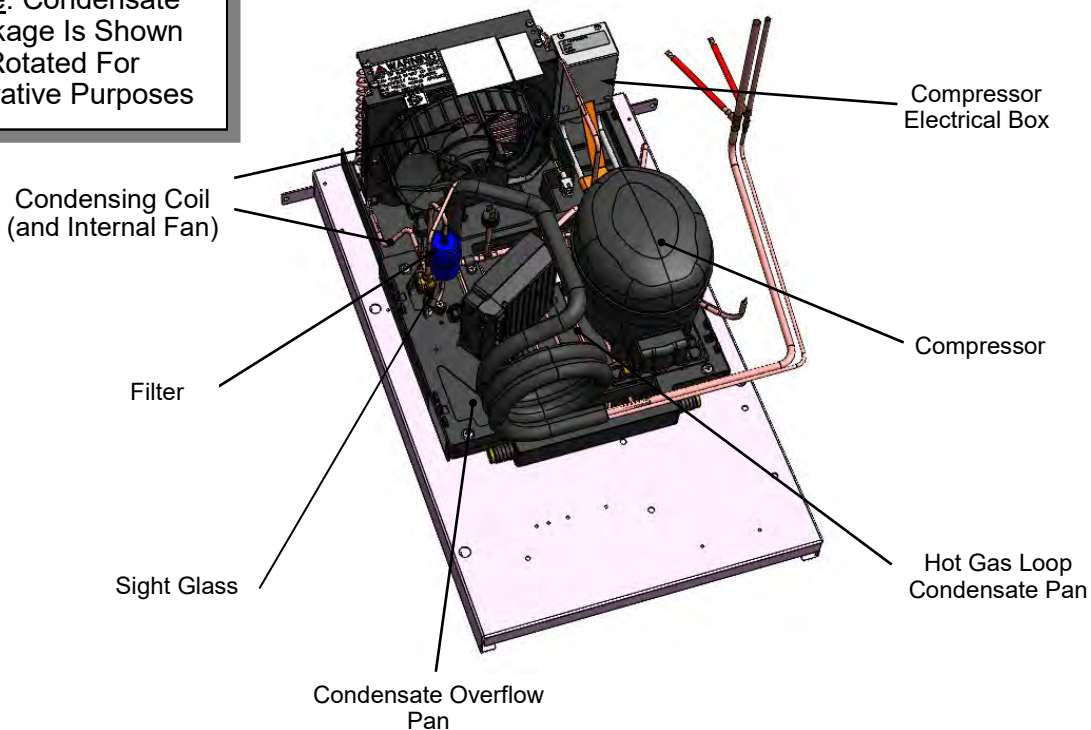

WARNING! TURN OFF CASE BEFORE PERFORMING PREVENTIVE MAINTENANCE!

ANNUAL (OR AS NEEDED) PREVENTIVE MAINTENANCE INSTRUCTIONS

Honeycomb Air Diffuser:

A. Wedge a non-metallic device of suitable strength (such as a ballpoint pen) between honeycomb and its housing. Caution! Use care not to dislodge the heating wire (that prevents condensation on the honeycomb retainer).

B. Apply pressure to collapse honeycomb to pull it out of honeycomb retainer.

C. Carefully pry downward and away from the honeycomb retainer.

D. Use brush to reach in and, with outward sweeping motion, pull any crumbs or residue out of honeycomb area.

> Clean honeycomb with warm water and soap solution. Submerge if necessary. Use brush to dislodge stubborn or sticky residue. Dry by using vacuum's blow mode.

E. After honeycomb has been thoroughly cleaned and dried, squeeze honeycomb to allow it to fit into the honeycomb retainer.

F. Carefully slide honeycomb into place.

G. Adjust honeycomb so it fits flat against retainer (not be wavy or out of position).

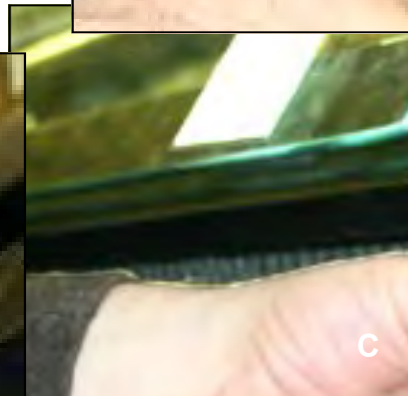
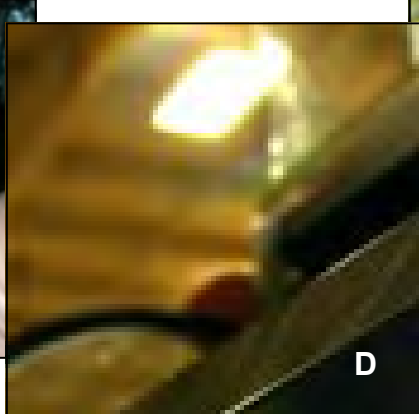
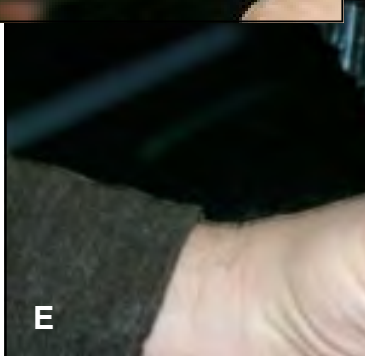
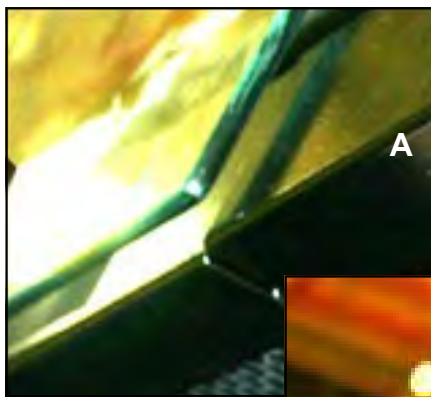
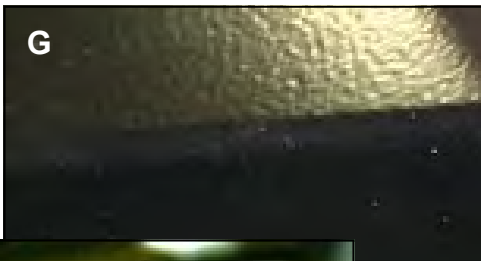

CONDITION	TROUBLESHOOTING
Water Is On The Floor	Call service provider.
Fan Emits Excessive Noise	Call service provider.
No Case Lights Are Working	Check that light switch is in the <i>on</i> position.
	Check that ALL of the light cords and plugs are properly connected. See LED LIGHT FIXTURES: REPAIR / REMOVAL / REPLACEMENT section in this manual for specifics.
	Check circuit breaker box for tripped circuit.
	If case lights still do not come on, call service provider.
Case Light Is Not Working	Check that ALL of the light cords and plugs are properly connected. This includes the following items:
	<ul style="list-style-type: none"> • Oval form of plug must connect to oval form of LED light. • See MAINTENANCE FUNDAMENTALS - LED LIGHT FIXTURE / LOCATION / REPAIR / REPLACEMENT section in this manual for more specifics including illustrations.
	If case light still does not come on, call service provider.
Case is Not Holding Proper Temperature	If a large amount of warm product was added to the case, it will take time for the temperature to adjust. Product must be pre-chilled before placing in case.
	Check that the case is not in the sun or near a heat or air-conditioning vent. See OVERVIEW / TYPE / COMPLIANCE / WARNINGS / PRECAUTIONS / WIRING / PLUGS section in manual for specifics.
	If case is located near front doors, temperature fluctuation can hinder unit's ability to maintain temperature. See OVERVIEW / TYPE / COMPLIANCE / WARNINGS / PRECAUTIONS / WIRING / PLUGS section in this manual for specifics.
	Check that filter and condenser coil has been cleaned. See GENERAL CLEANING (TO BE PERFORMED BY STORE PERSONNEL) section in this manual for specifics.
	Check air return grilles (area at front of decking) for obstructions. DO NOT set product on air grilles as this will prevent proper airflow!
	If case still is not holding proper temperature, call service provider.

LED Style Light Fixtures

Removal of faulty LED light:

- LED lights rarely require change-out.
- To remove faulty LED light, simply grasp light near retaining spring and carefully pull away from its spring. Disconnect plug from LED's socket.
- Contact Structural Concepts' Technical Service Department for replacement parts (see Technical Service section of this manual for information).

Replacement of LED light:

- To replace LED light fixture, simply insert new LED light at proper position (socket must be near plug). Carefully snap into metal springs so LEDs are held firmly in place.
 - **Note:** LED light and plug must be connected in a specific manner or they will not work.
- A. Certain plug designs ("barrel type") merely require that plug be pushed all the way in.
 - B. Other plugs require "oval edge" of plug to connect to oval edge of LED light.
- See illustrations below.

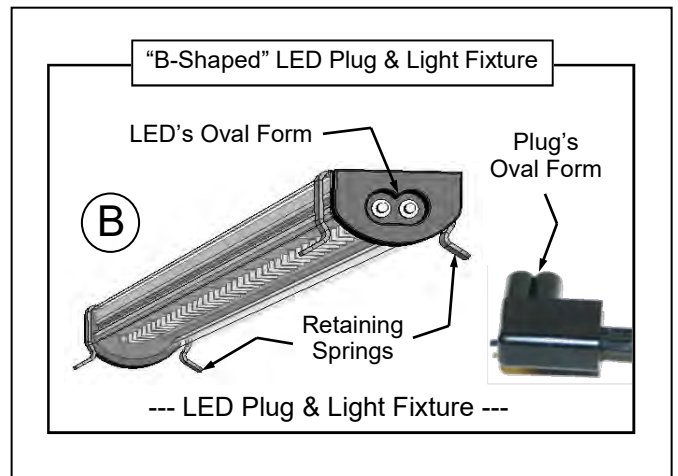
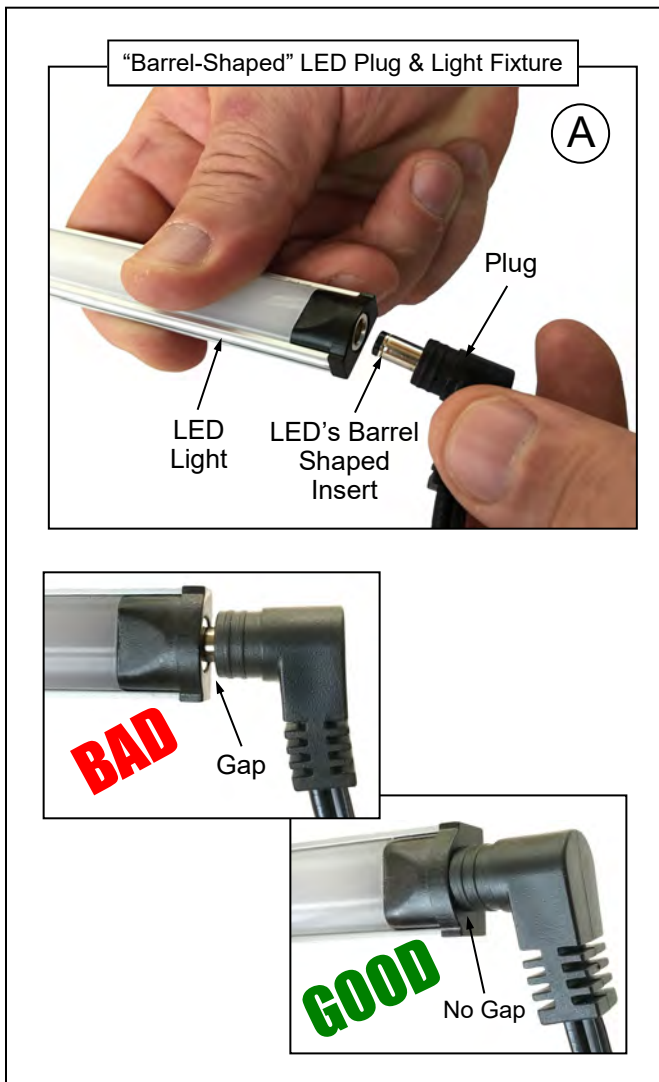



Serial Label Location & Information Listed / Technical Information & Service

- Serial labels are affixed at a wide range of places (on the header, near thermostat, at case rear, behind panels/toe-kicks, on electrical boxes, etc.).
- Serial labels contain electrical, temperature and refrigeration information, as well as regulatory standards to which the case conforms.

- Sample serial label is shown. A variety of models is displayed on serial label for illustration purposes only. Your case's serial label will reflect only one model.
- For additional technical information and service, see the *TECHNICAL SERVICE* page in this manual for instructions on contacting Structural Concepts' Technical Service Department.

Structural Concepts® **Fusion** MODEL NRS3648RXV-SAMPLE
 888 E. Porter Rd - Muskegon, MI 49441 SERIAL NO. 12345X30DZ098765

3048256
 Conforms to UL Std. 471
 Conforms to NSF/ANSI Stds. 2 & 7
 CERTIFIED TO CAN/CSA
 STD C22.2 NO 120

Super Heat Temp
 Defrost

Blend
Addenda
Harmony
Impulse
Oasis
Reveal

ELECTRICAL RATING
 REFRIGERANT
 DESIGN PRESSURE
 MINIMUM CIRCUIT AMPACITY
 MAXIMUM OVERCURRENT

120/1/60 16 A
 R513A AMOUNT 50 OZ
 HIGH 186 LOW 88
 20A
 20A

FOR PARTS AND SERVICE
 CALL 1-800-433-9490

Grocerant

SCAN FOR PRODUCT LITERATURE



Sample QR Code

--- Sample Serial Label For Refrigerated Cases ---



Determine Which Programmable Controller Is On Your Case (Controllers That Are Commonly Used By Structural Concepts Are Shown Below). Your Particular Programmable Controller May Differ.



Carel® PJEZ Platform



Carel® ir33 Platform



Carel® iJF Platform



Dixell® XM670K-XM679K Platform

To Access Information About The Programmable Controller That Is Used On Your Case, Follow These Instructions:

- > If Viewing This Document on Smart Phone, Tablet or Computer, Select/Click On The QR Code at Right.
- > If Viewing This Document In Print (Hard Copy), Scan The QR Code at Right With Your Smart Phone or Tablet.

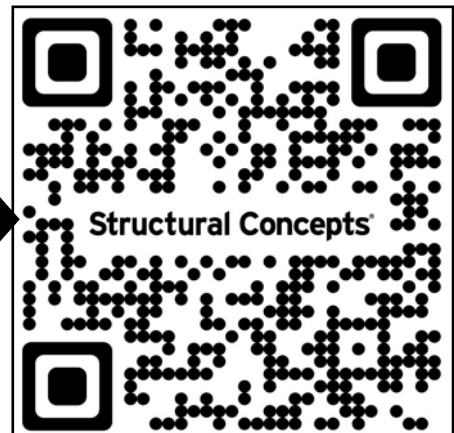
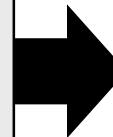

STRUCTURAL CONCEPTS TECHNICAL SERVICE CONTACT INFORMATION & LIMITED WARRANTY

TECH SERVICE/WARRANTY CONTACT INFO:
1 (800) 433-9490 / EXTENSION 1
DAYS/HOURS AVAILABLE:
MONDAY - FRIDAY (CLOSED HOLIDAYS)
8:00 AM to 8:00 PM EST

**YOU MUST HAVE THE FOLLOWING INFO AVAILABLE
BEFORE CONTACTING STRUCTURAL CONCEPTS:**
SERIAL NO. / MODEL NO. / STORE NO. / STORE
ADDRESS / DETAILS (PHOTOS, LEAK LOCATIONS,
DAMAGE, STORE'S AMBIENT CONDITIONS, ETC.)

**To Access The Limited Warranty To Your
Case, Follow These Instructions:**

- > If Viewing This Document on Smart Phone, Tablet or Computer, Select/Click On The QR Code at Right.
- > If Viewing This Document In Print (Hard Copy), Scan The QR Code at Right With Your Smart Phone or Tablet.

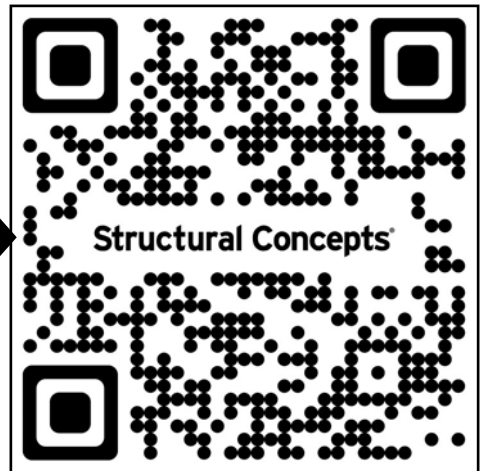
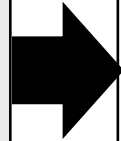

DATE DUE / COMMENTS: _____

DESCRIPTION: SELF-CONTAINED REFRIGERATED SERVICE / SELF-SERVE COU2765R & COU2765R.3749

WORK ORDER / SEQ No.	MODEL(S)	PART No.	SIZE(S)	COMMENTS
----------------------	----------	----------	---------	----------

ROUTINGS / SIGNOFF

ROUTED TO:	DEPARTMENT	INITIALS	SIGNOFF DATE	COMMENTS
TOM BROWN, JR.	PROJECT MGMT.	TBJ		
MEREDITH SIMERICK	PROD. ENGINEERING	MS		
FRED VANDONK'R	PROD. MANAGEMENT			
BERT OGBORN	TECHNICAL WRITER	BRO		

REVISIONS

REV.	DATE	BY	REVISION(S)
A	2.11.2013	BRO	RELEASE FOR PRODUCTION. Used P/N 20-21085 (Model CO43R.5597) as template.
B	2.28.2013	BRO	Added model CO33R to Manual.
C	5.16.2013	BRO	Added models CO53RM CI63R, CO3434RG.5716, CO3034RG.5718 and CO3034RG.5718A.
D	8.29.2013	BRO	Revised rear of model CO3434RG.5716 and cleaning instructions.
E	10.11.2013	BRO	Revised Numbering System on Page 11...Grrrrr!
F	4.23.2014	BRO	Added model CO43RM and CO63RM to manual.
G	8.1.2014	BRO	Added Model CO3436RG.5716; swapped Warranty Sheet.
H	8.25.2014	BRO	Enhanced skid removal, leveler adjustment instruction page.
I	12.9.2014	BRO	Added Model CO4324R. Added "Dishwasher Safe" aspect of condenser coil filter. Added Model CO4836RG.5716 (including BD3061.5716). Added load limit instruction sheet.
J	2.24.2015	BRO	Added Model CO3436R.5716. Minor typo on page 16 (model-wise). Revised Warranty sheet.
K	4.27.2015	BRO	Revised leveler info (as per casters); added CO3324R and CO6324R.
L	6.3.2015	BRO	Added "Counter Installation" information.
M	8.24.2015	BRO	Revised load line sheet.
N	11.29.2016	BRO	Revised adjoinment instructions as well as Warranty sheet.
O	6.19.2017	BRO	Revised per running changes. Added Models CO33RM and CO53RM.
P	8.18.2017	BRO	Added Model CO43R-FS (Free Standing Unit) with rear flip-down door.
Q	9.1.2017	BRO	Repaired Set Point Typo (was errantly stated that it should be 40° F. Revised Warranty Sheet. Also revised adjoinment sheet.
R	11.3.2017	BRO	Removed reference of a discharge opening chart on the <i>SIDE SECTION DIMENSIONAL AND LAYOUT FEATURES</i> sheet.
S	7.5.2018	BRO	Added Model CO3324R.7397 to cover sheet (and stated that it was similar to CO3324R).
T	11.26.2018	BRO	Added CA Prop 65 Chemical Warning Label. Revised Warranty Sheet. Reviewed/Removed Models. Added 'barrel-type' LED light illustrations.
U	6.18.2019	BRO	Revised load line information, O/W sheet and Warranty sheet. Added California mandated Refrigerant Disclosure Statement
V	8.13.2019	BRO	Revised Refrigerant Disclosure Statement to include "and approved."
W	9.26.2019	BRO	Showed optional front access condenser package.
X	6/8/2022	BRO	REVISION DESCRIPTION: REVISED MANUAL FOR QR CODE IMPLEMENTATION. REVAMPED DOCUMENT DESCRIPTION (NOW, USER MANUAL). CHANGED FILE NAME (P/N LISTED FIRST). REPLACED SCC LOGO (WITH NEW), SERIAL LABEL AND WARRANTY SHEET. REPLACED CAREL CONTROLLER SHEETS.

