

• NE3627RSSV2

36"L x 33"D x 27-7/8"H

Included

- NOTE: Glass warranty only applicable to first point of delivery
- Breeze~E (Type-II) self-contained refrigeration
- (2) Levels of clear glass shelving removable and adjustable on 1" centers
- Blue Fin coated coil
- Condensate pan (self-contained refrig. only)
- Integrated average product temperature of 40°F or less
- LED top & shelf lights
- NOTE: Overall case height is 51-1/8" (includes below counter)
- One piece formed ABS plastic tub
- One year parts & labor; 5 year compressor warranty



NE3627RSSV2

Specify	Standard Features	Additional Options
FRAME EXTERIOR COLOR	• Powder coated Silversan Black	• Powder coated (stock/non-stock colors) • Stainless steel
INTERIOR COLOR	• Powder coated Silversan Black	• NOTE: Interior color must be FDA & NSF approved • Powder coated (stock colors, specify RAL#) • Stainless steel
BASE	• Slide in counter assembly	
LIGHTS	• LED 3500K w/ frosted lens	• LED 3000K w/ frosted lens • LED 4000K w/ frosted lens
ELECTRICAL CONNECTION	• 10' Straight blade power cord (self-cont.)	• 10' Locking power cord (self-cont.) • Electrical leads (remote)
REFRIGERATION	• Breeze~E (Type-II) self-contained refrigeration (rear access)	• Breeze~E (Type-II) self-contained refrigeration (front access) • Remote w/thermostat, solenoid & TXV (front access) • Remote w/thermostat, solenoid & TXV (rear access)
MISCELLANEOUS		• Second year parts & labor warranty (excludes compressor)
ACCESSORIES		• Clean Sweep® coil cleaner (self-cont.) • Removable clear acrylic security cover, locking

Intended Environment: Type II - Designed to operate in ambient conditions of 80°F and 55% relative humidity unless noted otherwise in system information below.		
Zone	Intended Product To Be Displayed	Warmest Avg Prod Temp ° F
1	Packaged refrigerated products	40

PLAN VIEW

SIDE VIEW

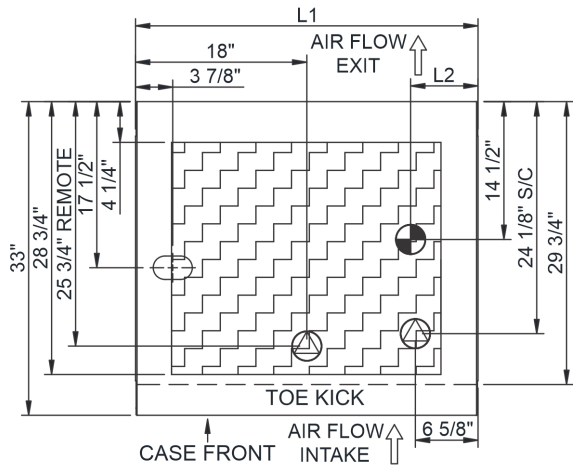

NOTE: SELF-CONTAINED REFRIGERATION CONNECTIONS ONLY ACCESSIBLE BY PULLING OUT CONDENSER DRAWER

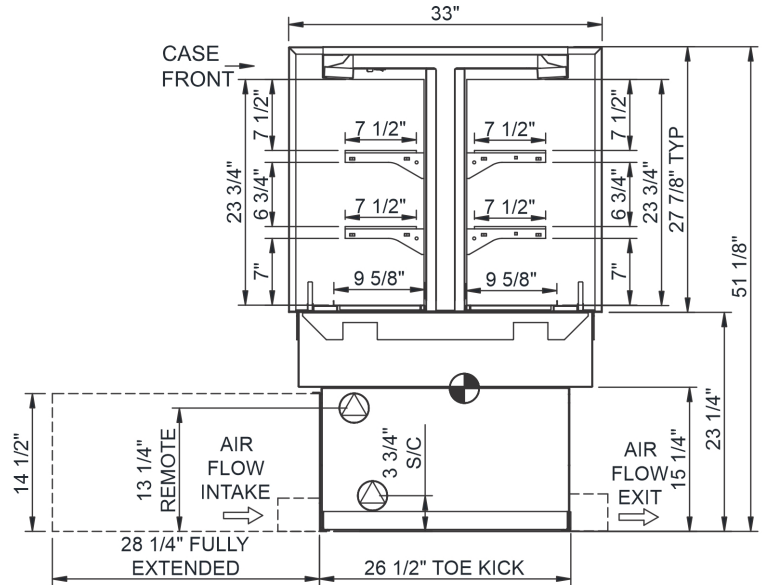

NOTE: ALL DIMENSIONS APPROXIMATE

- ELECTRICAL JUNCTION BOX (SUPPLIED WITH 6" LEADS OR POWER CORD).
- LOCATION OF DRAIN TUBE FOR REMOTE REF. ONLY (SUPPLIED WITH 3/4" OR 1 1/2" PVC TUBE).

- REFRIGERATION LINE CONNECTION.
- REMOTE FLOOR SINK & UTILITIES ACCESS AREA.

- SELF-CONTAINED CASE SERVICE ACCESS AREA.
- DRY CASE SERVICE ACCESS AREA.

Model Technical Specifications																
Model	L"	L1"	L2"	System Circuit Volts		Phs	Freq	Amps ***	Watts	Wires	NEMA Plug	SST	Conv. Rack BTUH	Para. Rack BTUH	Est Wt	
NE3627RSSV2	N/A	36.00	7.13	Remote (DX)	Circuit #1	110-120	1	60	1.68	57	2+G	Leads Single	20.00	4622	4280	675
				Self-Contained (R513A)	Circuit #1	208-240	1	60	10.98	1,565	2+G	6-15P or L6-15P	N/A	N/A	N/A	

*** Does not include electric defrost on freezer models.

Regulatory Approvals:	
All Models	Accordance with AHRI Std 1200 ETL Listed to UL 471 ETL Listed to CAN/CSA 22.2 No. 120 ETL Sanitation to NSF/ANSI 7



In Accordance with
AHRI Std 1200

DOE 2017
Energy Efficiency
Compliant

Important Notes:

- ELECTRICAL NOTE: If GFCI is required, a GFCI breaker MUST be used in lieu of a GFCI receptacle
- Back side of counter must be open or vented the full length of the unit to allow proper ventilation for the refrigeration system.
- Glass warranty only applicable to first point of delivery.
- Compressor air intake from rear and out front panel at toe kick. Front panel cannot be blocked.

⚠ WARNING: This product can expose you to chemicals, including Urethane (Ethyl Carbamate), which are known to the State of California to cause cancer and birth defects or other reproductive harm. For more information go to www.P65Warnings.ca.gov.