

- **P43941R** 51"L x 39-3/8"D x 39-3/8"H
- **P63941R** 75-3/8"L x 39-3/8"D x 39-3/8"H
- **P83941R** 99-3/4"L x 39-3/8"D x 39-3/8"H

### Included

- Breeze self-contained refrigeration
- Black rear exterior
- Compressor air rear intake, front discharge. Toe kick cannot be blocked
- Digital fahrenheit thermometer
- One year parts & labor; 5 year compressor warranty
- Open reach-in front
- Warmest average product temperature of 40°F or less



**P43941R**

Specify	Standard Features	Additional Options
<b>EXTERIOR COLOR</b>	• Laminate (stock colors)	• Laminate (non-stock colors) • Powder coated (stock colors, specify RAL#) • Stainless steel
<b>INTERIOR COLOR</b>	• Powder coated Silversan Black	• Stainless steel
<b>BASE</b>	• Casters w/ levelers (self-cont.)	• Rail system for shims (remote)
<b>BUMPER END</b>	• None	• Bumper on end (matches front bumper) (1 row)
<b>BUMPER FRONT</b>	• None	• 1" Boston bumper (specify color)
<b>DISPLAY</b>	• None	<sup>1</sup> • 3"H Display risers (2 levels) • Metal shelf, 12"D, non-lighted
<b>END PANELS</b>	• Full w/stainless steel mirror interior	• None (synchronized defrost required)
<b>UPPER REAR OUTSIDE SHELF</b>	• None	<sup>2</sup> • Metal shelf, 14"D, lighted
<b>ELECTRICAL CONNECTION</b>	• 6' Straight blade power cord (self-cont.)	• Electrical leads (remote)
<b>REFRIGERATION</b>	• Breeze self-contained refrigeration	<sup>3</sup> • Remote DX ref w/ standard coil
<b>SENSOR</b>	• None	• CPC discharge air sensor (remote)
<b>MISCELLANEOUS</b>		• Second year parts & labor warranty (excludes compressor)

**Option Notes:** 1 - N/A with display metal shelf  
 2 - Increases overall height  
 3 - Read important notes for remote options

<b>Intended Environment:</b> Type I - Designed to operate in ambient conditions of 75°F with 55% relative humidity unless noted otherwise in system information below.		
<b>Zone</b>	<b>Intended Product To Be Displayed</b>	<b>Warmest Avg Prod Temp ° F</b>
1	Packaged refrigerated products-Prechilled to Warmest Avg Prod Temp.	40

### PLAN VIEW

### SIDE VIEW

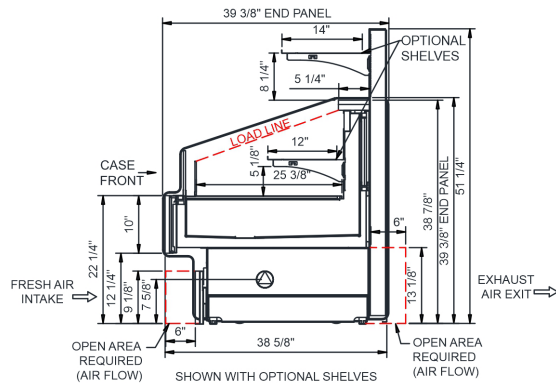
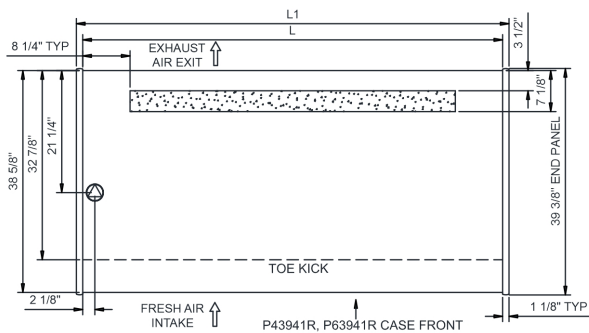
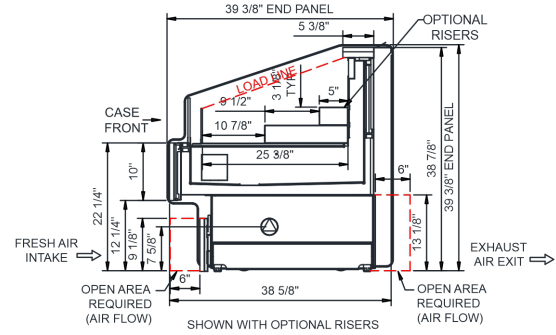
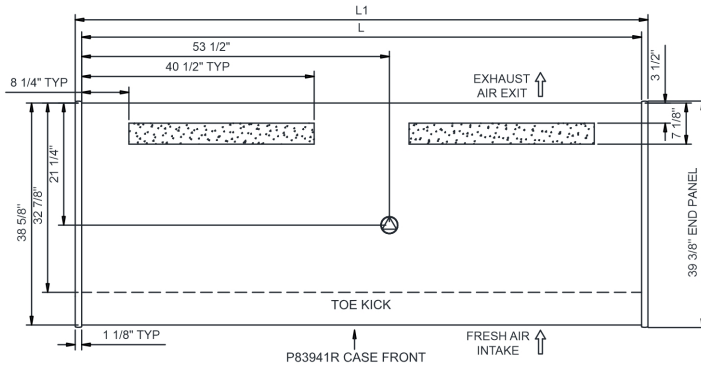

NOTE: ALL DIMENSIONS APPROXIMATE

- ELECTRICAL JUNCTION BOX (SUPPLIED WITH 6" LEADS OR POWER CORD).
- LOCATION OF DRAIN TUBE FOR REMOTE REF. ONLY (SUPPLIED WITH 3/4" OR 1 1/2" PVC TUBE).

- REFRIGERATION LINE CONNECTION.
- REMOTE FLOOR SINK & UTILITIES ACCESS AREA.

- SELF-CONTAINED CASE SERVICE ACCESS AREA.
- DRY CASE SERVICE ACCESS AREA.

Model Technical Specifications																
Model	L"	L1"	L2"	System Circuit Volts		Phs	Freq	Amps ***	Watts	Wires	NEMA Plug	SST	Conv. Rack BTUH	Para. Rack BTUH	Est Wt	
P43941R	48.75	51.00	.00	Remote (DX)	Circuit #1	110-120	1	60	0.49	43	2+G	Leads Multiple	20.00	1949	1805	765
				Self-Contained (R290)	Circuit #1	110-120	1	60	15.24	1,573	2+G	5-20P or L5-20P	N/A	N/A	N/A	
P63941R	73.13	75.38	.00	Remote (DX)	Circuit #1	110-120	1	60	0.91	77	2+G	Leads Multiple	20.00	2873	2660	985
				Remote (GLYCOL 35%)	Circuit #1	110-120	1	60	0.86	60	2+G	Leads Multiple	20.00	2873	2660	
				Self-Contained (R290)	Circuit #1	110-120	1	60	15.32	1,583	2+G	5-20P or L5-20P	N/A	N/A	N/A	
P83941R	97.50	99.75	.00	Remote (DX)	Circuit #1	110-120	1	60	0.98	86	2+G	Leads Multiple	20.00	3847	3562	1,400
				Self-Contained (R290)	Circuit #1	208-240	1	60	16.00	2,758	2+G	6-20P or L6-20P	N/A	N/A	N/A	

\*\*\* Does not include electric defrost on freezer models.

#### Regulatory Approvals:

All Models  
 Accordance with AHRI Std 1200  
 ETL Listed to UL 471  
 ETL Listed to CAN/CSA 22.2 No. 120  
 ETL Sanitation to NSF/ANSI 7



In Accordance with  
**AHRI Std 1200**

**DOE 2017**  
 Energy Efficiency  
 Compliant

#### Important Notes:

- 1) REMOTE REFRIGERATION NOTE: Condensing unit not included, floor drain required.
- 2) ELECTRICAL NOTE: If GFCI is required, a GFCI breaker MUST be used in lieu of a GFCI receptacle.
- 3) 44" Minimum door entry clearance required (Without shipping skid).
- 4) Remote units must be shimmed during installation to ensure the unit is level and plumb.

**⚠ WARNING:** This product can expose you to chemicals, including Urethane (Ethyl Carbamate), which are known to the State of California to cause cancer and birth defects or other reproductive harm. For more information go to [www.P65Warnings.ca.gov](http://www.P65Warnings.ca.gov).