

- NR3647RSV 35-3/4"L x 33"D x 47-1/4"H
- NR4847RSV 47-3/4"L x 33"D x 47-1/4"H
- NR6047RSV 59-3/4"L x 33"D x 47-1/4"H
- NR7247RSV 71-3/4"L x 33"D x 47-1/4"H

### Included

- NOTE: Glass warranty only applicable to first point of delivery
- Breeze~E (Type-II) self-contained refrigeration
- (2) Levels of clear glass shelving removable and adjustable on 1" centers
- Condensate pan (self-contained refig. only)
- LED top & shelf lights
- One piece formed ABS plastic tub
- One year parts & labor; 5 year compressor warranty
- Vertical, fixed front & side UV bonded frameless glass
- Warmest average product temperature of 40°F or less



NR4847RSV

Specify	Standard Features	Additional Options
<b>FRAME EXTERIOR COLOR</b>	• Powder coated Silversan Black	• Powder coated (stock/non-stock colors) • Stainless steel
<b>INTERIOR COLOR</b>	• Powder coated Silversan Black	• NOTE: Interior color must be FDA & NSF approved • Powder coated (stock colors, specify RAL#) • Stainless steel
<b>LOWER FRONT PANEL COLOR</b>	• Powder coated Silversan Black	• Powder coated (stock colors, specify RAL#) • Stainless steel
<b>PANEL EXTERIOR</b>	• Black	• Laminate (stock/non-stock colors) • Stainless steel
<b>BASE SUPPORT</b>	• Casters (non-locking) w/ levelers (self-cont.)	• 6"H legs (self-cont.) • Shims (remote)
<b>END PANELS</b>	• Full end panel	• None (specify per line-up)
<b>LOWER REAR PANEL</b>	• Powder coated Silversan Black	• Powder coated (stock colors, specify RAL#) • Stainless steel
<b>REAR DOORS</b>	• Clear glass rear sliding doors	• Reflective glass rear sliding doors
<b>LIGHTS</b>	• LED 3500K w/ frosted lens	• LED 3000K w/ frosted lens • LED 4000K w/ frosted lens
<b>ELECTRICAL CONNECTION</b>	• 10' Straight blade power cord (self-cont.)	• 10' Locking power cord (self-cont.) • Electrical leads (remote)
<b>REFRIGERATION</b>	• Breeze~E (Type-II) self-contained refrigeration (rear access)	• Breeze~E (Type-II) self-contained refrigeration (front access) <sup>1</sup> • Remote w/thermostat, solenoid & TXV (front access) <sup>2</sup> • Remote w/thermostat, solenoid & TXV (rear access)
<b>MISCELLANEOUS</b>		<sup>3</sup> • 14.5" Base height extension • Rear door lock • Second year parts & labor warranty (excludes compressor)
<b>ACCESSORIES</b>		• Clean Sweep® coil cleaner (self-cont.)

**Option Notes:** 1 - Read important notes for remote options  
2 - Read important notes for remote options  
3 - Cannot be combined w/ 6"H legs

<b>Intended Environment:</b> Type II - Designed to operate in ambient conditions of 80°F and 55% relative humidity unless noted otherwise in system information below.		
<b>Zone</b>	<b>Intended Product To Be Displayed</b>	<b>Warmest Avg Prod Temp ° F</b>
1	Unpackaged refrigerated products-Prechilled to Warmest Avg Prod Temp.	40

**PLAN VIEW**

**SIDE VIEW**

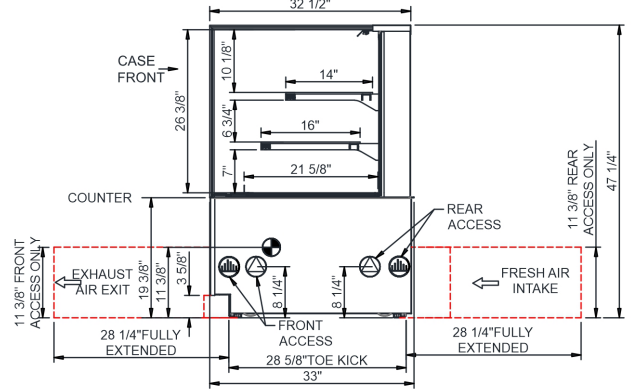
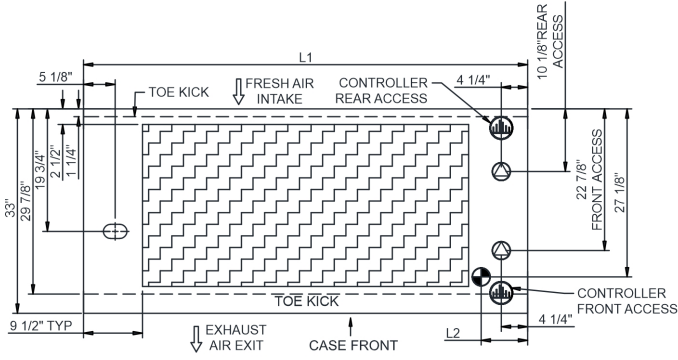

	"A"	"B"	"C"	"D"		"M"	"N"
NR3647RSV	8 1/2"	16 3/4"	8 1/2"	10 3/8"	NR3647RSV	15 3/8"	25 1/4"
NR4847RSV	8 1/2"	28 3/4"	8 1/2"	10 3/8"	NR4847RSV	21 3/8"	25 1/4"
NR6047RSV	8 1/2"	40 3/4"	8 1/2" x2	10 3/8"	NR6047RSV	27 3/8"	25 1/4"
NR7247RSV	8 1/2"	52 3/4"	8 1/2" x2	10 3/8"	NR7247RSV	33 3/8"	25 1/4"

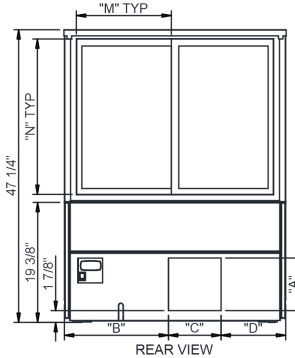

- NOTES:**
- 11 3/8" TALL, FULL WIDTH OF CASE OPENING IN CABINET OR COUNTER IS REQUIRED TO PULL OUT REFRIGERATION SYSTEM.
  - BACK OF COUNTER / CABINET MUST BE VENTED PROPERLY FOR ADEQUATE AIRFLOW TO CONDENSER.
  - REPRESENTS REAR PULLOUT REFRIGERATION. AIR FLOW INTAKE AND EXIT DETAILS ARE REVERSED WITH FRONT PULLOUT REFRIGERATION OPTION.
  - SELF-CONTAINED ACCESS ONLY BY PULLING OUT CONDENSER UNIT.
  - 4" OPEN AREA CLEARANCE REQUIRED FOR AIR FLOW FRONT AND REAR OF CASE.

**NOTE: ALL DIMENSIONS APPROXIMATE**

- ELECTRICAL JUNCTION BOX (SUPPLIED WITH 6" LEADS OR POWER CORD).**
- REFRIGERATION LINE CONNECTION.**
- SELF-CONTAINED CASE SERVICE ACCESS AREA.**
- LOCATION OF DRAIN TUBE FOR REMOTE REF. ONLY (SUPPLIED WITH 3/4" OR 1 1/2" PVC TUBE).**
- REMOTE FLOOR SINK & UTILITIES ACCESS AREA.**
- DRY CASE SERVICE ACCESS AREA.**

Model Technical Specifications																
Model	L"	L1"	L2"	System Circuit Volts		Phs	Freq	Amps ***	Watts	Wires	NEMA Plug	SST	Conv. Rack BTUH	Para. Rack BTUH	Est Wt	
NR3647RSV	N/A	35.75	7.50	Remote (DX)	Circuit #1	110-120	1	60	1.08	35	2+G	Leads Single	24.00	1015	940	650
				Self-Contained (R290)	Circuit #1	110-120	1	60	10.73	959	2+G	5-15P or L5-15P	N/A	N/A	N/A	
NR4847RSV	N/A	47.75	7.50	Remote (DX)	Circuit #1	110-120	1	60	1.08	39	2+G	Leads Single	24.00	1318	1220	950
				Self-Contained (R290)	Circuit #1	110-120	1	60	11.18	987	2+G	5-15P or L5-15P	N/A	N/A	N/A	
NR6047RSV	N/A	59.75	7.50	Remote (DX)	Circuit #1	110-120	1	60	1.38	58	2+G	Leads Single	20.00	1620	1500	1,000
				Self-Contained (R290)	Circuit #1	110-120	1	60	11.18	994	2+G	5-15P or L5-15P	N/A	N/A	N/A	
NR7247RSV	N/A	71.75	7.50	Remote (DX)	Circuit #1	110-120	1	60	1.38	62	2+G	Leads Single	20.00	1922	1780	1,150
				Self-Contained (R290)	Circuit #1	110-120	1	60	15.48	1,529	2+G	5-20P or L5-20P	N/A	N/A	N/A	

\*\*\* Does not include electric defrost on freezer models.

Regulatory Approvals:	
All Models	Accordance with AHRI Std 1200 ETL Listed to UL 471 ETL Listed to CAN/CSA 22.2 No. 120 ENERGY STAR® ETL Sanitation to NSF/ANSI 7

**Important Notes:**

- 1) REMOTE REFRIGERATION NOTE: Condensing unit not included, floor drain required.
- 2) ELECTRICAL NOTE: If GFCI is required, a GFCI breaker MUST be used in lieu of a GFCI receptacle
- 3) Back side of counter must be open or vented the full length of the unit to allow proper ventilation for the refrigeration system.
- 4) Glass warranty only applicable to first point of delivery.
- 5) Compressor air intake from rear and out front panel at toe kick. Front panel cannot be blocked.

**⚠ WARNING:** This product can expose you to chemicals, including Urethane (Ethyl Carbamate), which are known to the State of California to cause cancer and birth defects or other reproductive harm. For more information go to [www.P65Warnings.ca.gov](http://www.P65Warnings.ca.gov).

