

Impulse![™]
S E R I E S

INSTALLATION & OPERATING MANUAL

PN 54199

SERVICE COUNTER TOP AMBIENT MERCHANDISER

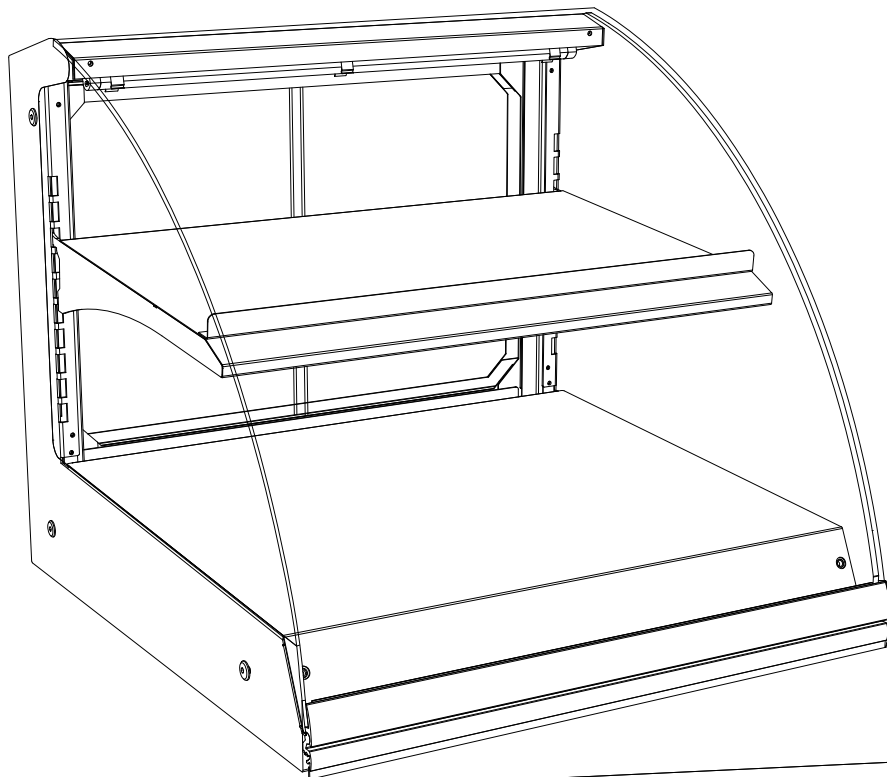

**Model DG2422.5171
Shown At Left**

**Model DG2422
Shown At Right**

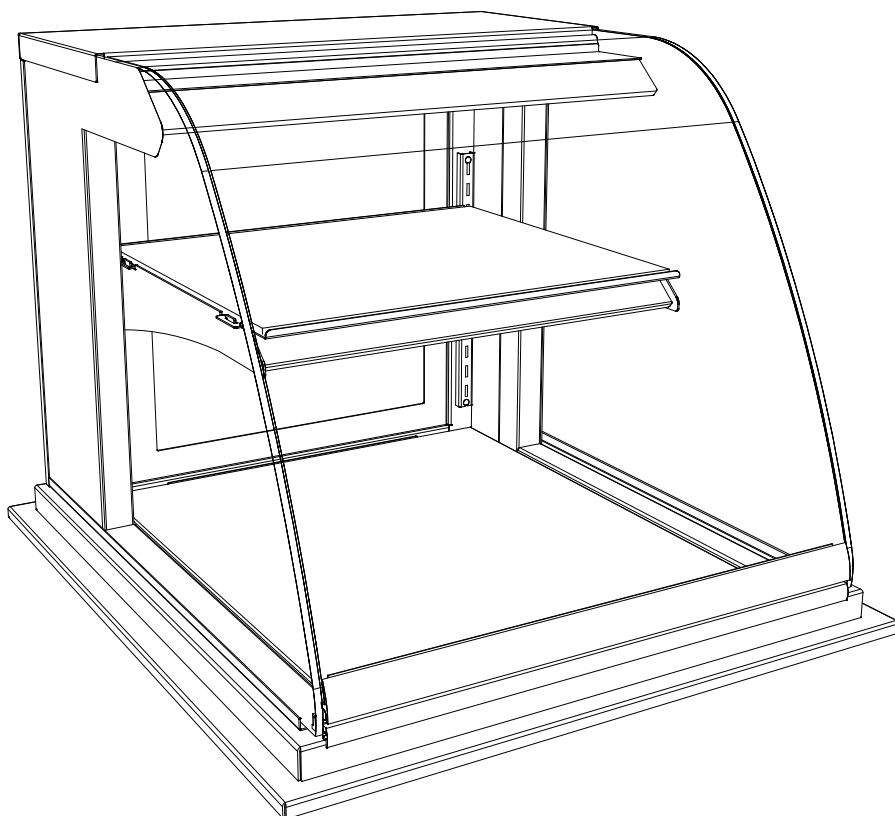

Model DG2422.5171
24" L x 25" D x 22" H

Model DG2422
26 1/8" L x 28 5/8" D x 21 1/2" H

Model DG3622
38 1/8" L x 28 5/8" D x 21 1/2" H



Structural

Concepts

888 E. Porter Road · Muskegon, MI 49441 Phone: 231.798.8888 Fax: 231.798.4960 www.structuralconcepts.com

TABLE OF CONTENTS

OVERVIEW / COMPLIANCE / WARNINGS / PRECAUTIONS	3
MERCHANDISER PLACEMENT / POWER CORD HOLE LOCATION / LIGHT SWITCH	4
FRONT GLASS OPENING / SHELF & DECK REMOVAL / SCREW PLACEMENT / SEALING TO COUNTER	5
STANDARD FLUORESCENT LIGHT FIXTURES / LED LIGHT FIXTURES	6
REMOVING REAR SLIDING DOORS / ELECTRICAL BOX / LIGHT BALLAST ACCESS	7
MODEL DG2422.5171 REAR STORAGE / MODEL DG2422 (STANDARD MODEL ONLY) HINGED DOOR OPENING	8
GENERAL CLEANING [TO BE PERFORMED BY STORE PERSONNEL]	9
TROUBLESHOOTING	10
SERIAL LABEL LOCATION & INFORMATION LISTED / TECH INFO & SERVICE	11
TECHNICAL SERVICE CONTACT INFORMATION & WARRANTY INFORMATION	12

OVERVIEW / COMPLIANCE / WARNINGS / PRECAUTIONS

OVERVIEW

- The Structural Concepts Impulse™ Service Counter Top Ambient Merchandiser is designed to merchandise packaged products at ambient temperatures.
- Improper use will void warranty.
- This unit is designed for the display of products in ambient store conditions where temperatures and humidity are maintained at a maximum of 75 °F and 55% relative humidity.

COMPLIANCE

- Performance issues when in violation of applicable

NEC, federal, state or local electrical codes are not covered by warranty.

- See compliance specifics below.

WARNINGS

- Following are important warnings to prevent injury or death.
- Please read carefully!

PRECAUTIONS

- Following are important precautions to prevent damage to unit or merchandise.



**ATTENTION
INSTALLER**

WARNING

**ELECTRICAL
HAZARD**



CAUTION

CAUTION



COMPLIANCE

This equipment **MUST** be installed in compliance with all applicable NEC, federal, state and local electrical codes.

WARNING

Risk of electric shock.

Disconnect ALL ELECTRICAL SOURCES before servicing.

CAUTION

LED lamps reflect specific size, shape and overall design. Any replacements must meet factory specifications.

CAUTION

Fluorescent lamps have been treated to resist breakage and must be replaced with similarly treated lamps.

CAUTION

If N.E.C. (National Electric Code) or your local code requires GFCI (Ground Fault Circuit Interrupter) protection, the use of a GFCI breaker is strongly recommended.

MERCHANDISER PLACEMENT / POWER CORD HOLE LOCATION / LIGHT SWITCH

Merchandiser Placement

- Merchandiser must be placed on counter with location of power cord taken into consideration.
- Standard Models DG2422 & DG3622 Only: Power cord is located at customer left, case rear corner (as shown in top-left illustration).
- Model DG2422.5171 Only: Power cord is located at center of unit

Hole Location

- Counter must have 1-1/2" diameter hole drilled **AT A SPECIFIC LOCATION** to allow power cord to go through counter without hindrance.
- Illustrations show dimensions at which power cord exits case.
- Models DG2422 and DG3622: Dimensions to power cord are from case rear and from customer-left edge of display. The 1-1/2" diameter hole (drilled in counter) must be located directly below this location. See illustration at top-right.
- Model DG2422.5171: Dimensions to power cord are from case front and from either side inside edge of base pan (as it is symmetrical). See illustration at mid-right.
- Once case is positioned in proper location, connect power cord to a certified electrical outlet with ground.

Light Switch

- Turn on the lights. Light switch is in the upper display interior of the case at rear right side (see illustration below).
- See next page for instructions on attaching and sealing merchandiser to counter top.

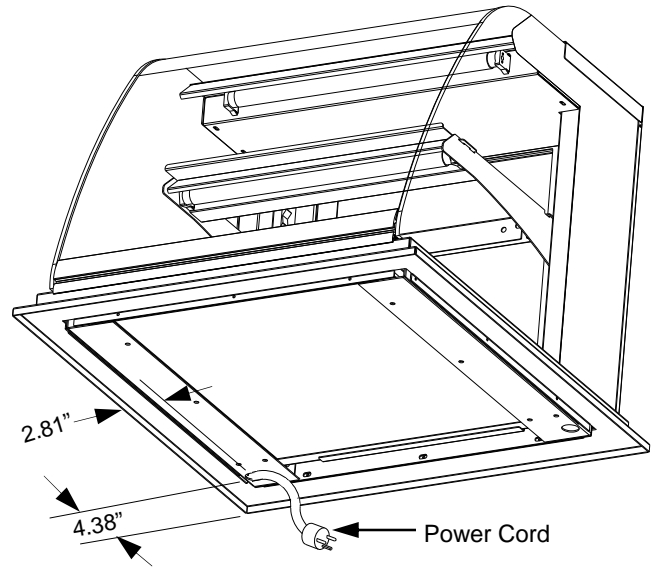

View of Power Cord Location For Models DG2422 & DG3622 Only (Shown in Above Illustration)

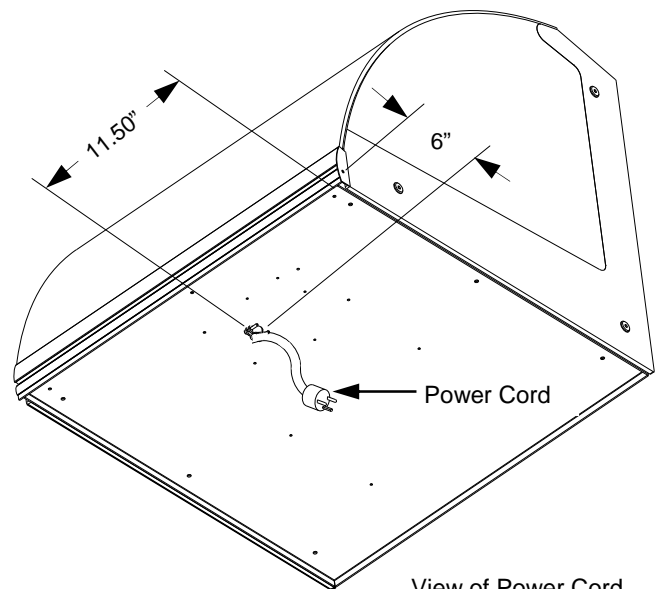

View of Power Cord Location For Model DG2422.5171 Only (Shown in Above Illustration)

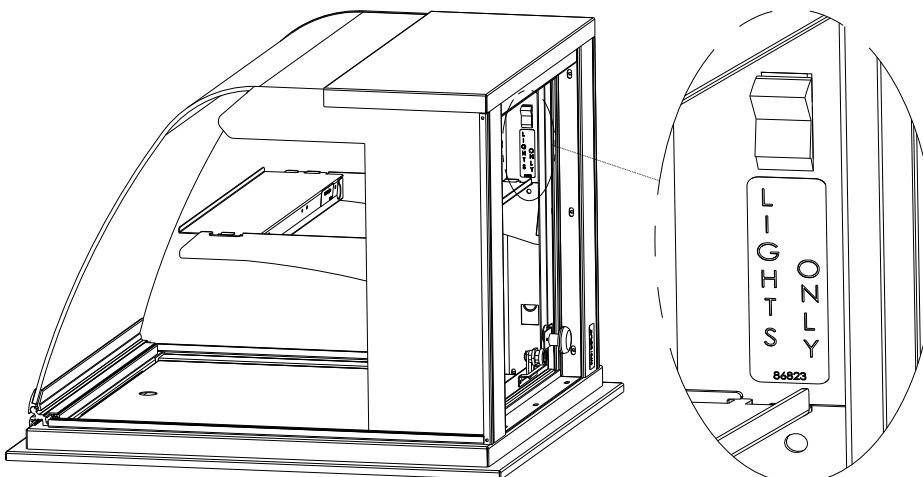

All Models: View of Merchandiser And Light Switch Location

FRONT GLASS OPENING / SHELF & DECK REMOVAL / SCREW PLACEMENT / SEAL TO COUNTER

Front Glass Opening

- Front Glass can be opened for cleaning or to access shelving, etc.
- Caution! Do not lean on glass in its open position.
- See illustrations at top-right and mid-right.

Shelf Assembly Removal

- Shelves can be removed for cleaning or adjustments
- For lighted shelving, unplug the light cord.
- Lift shelf straight up to separate from brackets.
- Remove brackets. Note: It may be necessary to remove the nylon shipping bracket retainer. Pliers will be required to accomplish this task.

Deck Removal

- Rotate merchandiser's curved front glass forward to allow access to deck.
- Using finger hole, lift deck up and out of merchandiser.
- See illustration at top right.

Screw Placement

- Use six (6) #12 x 3/4 long "type A-B" wood screws with heads of at least .32"Ø (to prevent head from passing through holes).
- Insert screws through holes and screw into counter top.
- Tighten securely.
- See illustration at lower-right.

Sealing To Counter

- Use transparent (or color to match counter top) industrial grade silicone to seal merchandiser to counter.
- See photo below-left for silicone sample.
- Place a thin bead (approximately 3/16") along entire length (all four sides) of support ledge.
- Allow to dry before allowing contact.

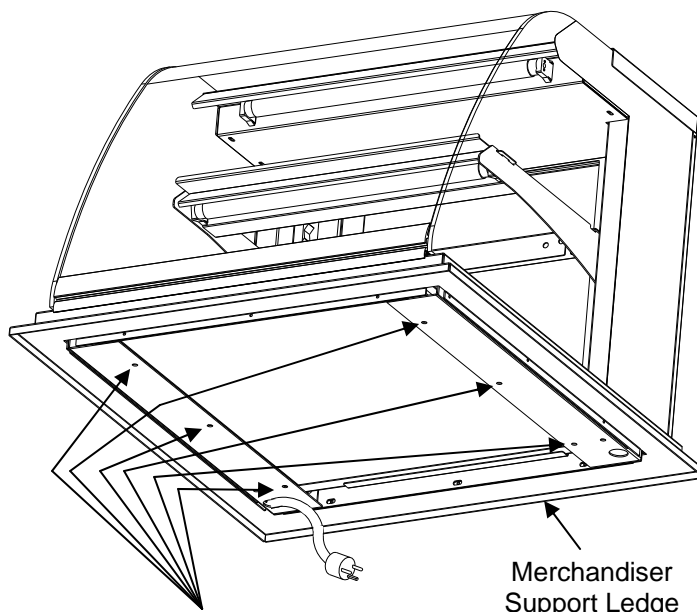
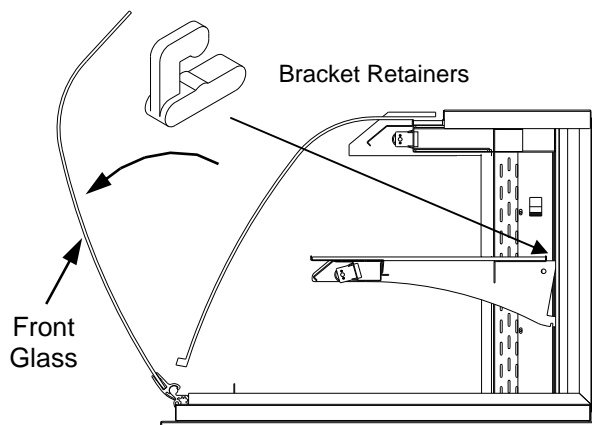
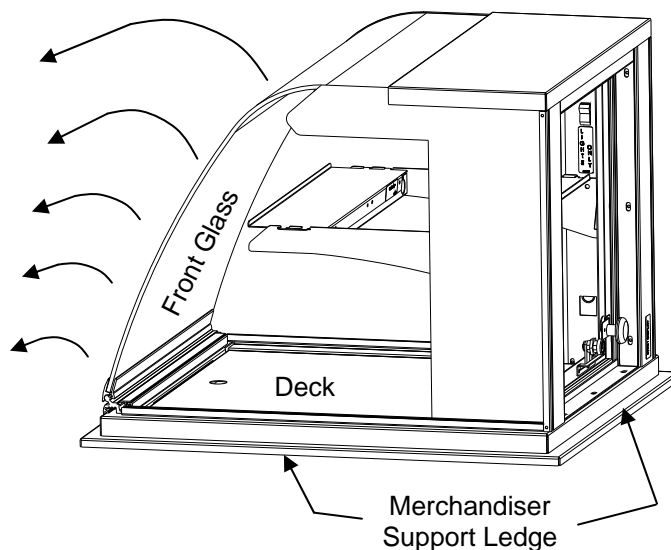

.28"Ø holes provided for #12 x 3/4 long "type A-B" wood screws with at least .32"Ø heads.

STANDARD FLUORESCENT LIGHT FIXTURES / LED LIGHT FIXTURES

Standard Fluorescent Light Fixtures

Light fixtures are located at the top inside of case (from the front) and may be provided on the underside of each shelf assembly

Removal of lamp:

- Rotate lamp (1/4 turn) so that pins are aligned in slots and remove bulb.

Installation of lamp:

- Align pins with slot.
- Insert pins into socket and rotate 1/4 turn to secure pin contacts in socket.

See illustrations at top-right.

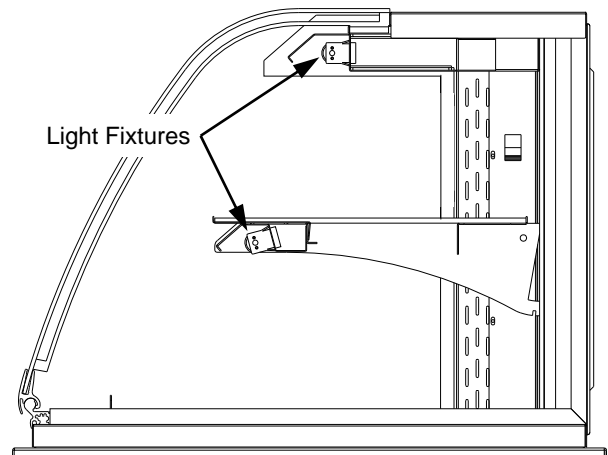

LED Light Fixtures

Removal of lamp:

- If case is provided with LED lights, they will rarely require change-out.
- Contact Structural Concepts' Technical Service Department for replacement parts (see the Technical Service section of operating manual).

Replacement of lamp:

- To replace LED Light Fixture, simply disconnect the existing LED light from its brackets and/or self-adhesive tape. Replace.
- **Note:** LED Light and Plug must be connected in a specific manner or they will not work.
- Make certain flat edge of plug connects to flat edge of LED light.
- See illustrations at lower right.

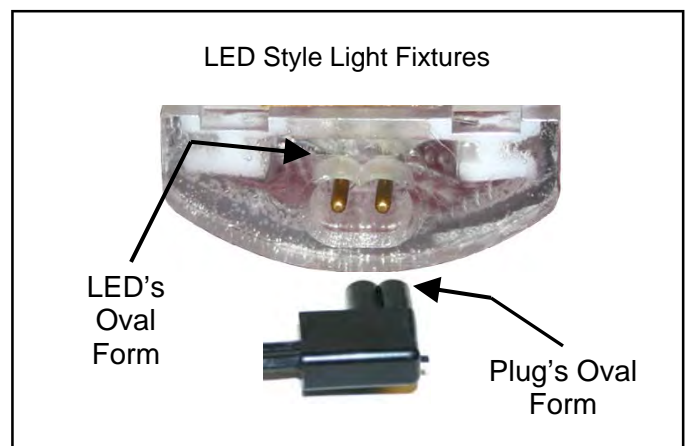
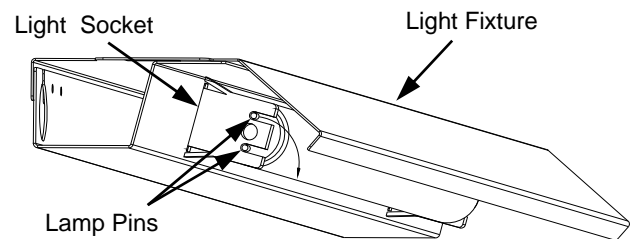

REMOVING REAR SLIDING DOORS / ELECTRICAL BOX / LIGHT BALLAST ACCESS

Removing the Rear Doors (Standard Model DG2422.5171 and Model DG3622 Only).

- **Note: Doors are not interchangeable.**
- There is an inner and outer door. Outer must be removed first and replaced last.
- Outer door is the right hand door (from the service side or rear of the case). It can be identified by a stop located at the lower right hand corner to the inside of the case.
- Move doors toward the center of case.
- Lift each door up toward the top of the case and pivot the bottom of the door out.
- **Note: See next page for Model DG2422 (Standard Model Only) Hinged Door Opening.**

Light Ballasts / Electrical Box

Warning! Disconnect power before providing maintenance and service to unit. Assembly or disassembly and servicing to be accomplished by a licensed electrical contractor.

Light Ballast Access (Standard Models DG2422 and DG3622 Only)

- Light ballast is located along customer-left in Light Switch housing.
- See illustration at top-right.

Electrical Box and Light Ballast Access (Model DG2422.5171 Only)

- Electrical box and LED light ballast is located at underside of deck pan.
- Remove deck pan (by removing two screws at case front) to access electrical box.
- See illustrations at lower-left and lower-right.

Light Ballast (Behind Light Switch Housing) on Standard Models DG2422 and DG3622 Only

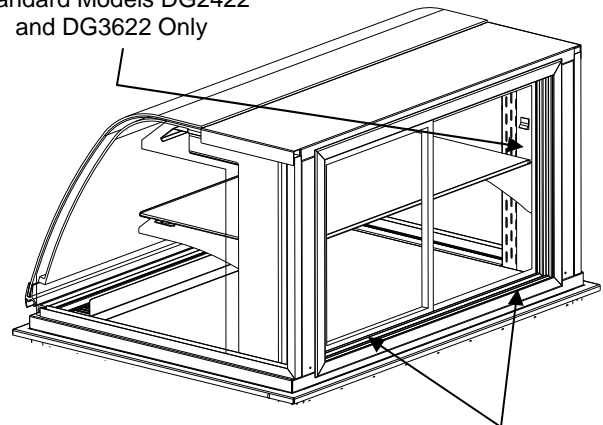

Inner and Outer Rear Sliding Doors Models DG3622 and DG2422.5171 Only

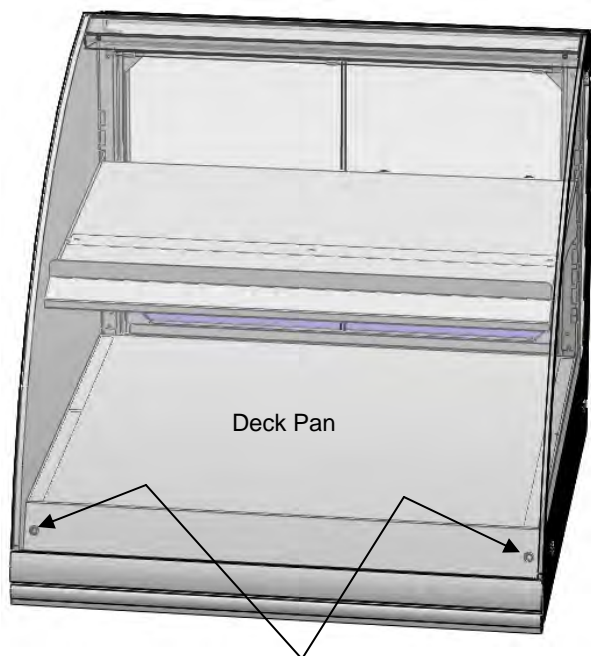

Remove Two (2) Screws at Case Front to Disconnect & Remove Deck Pan From Case (Model DG2422.5171)

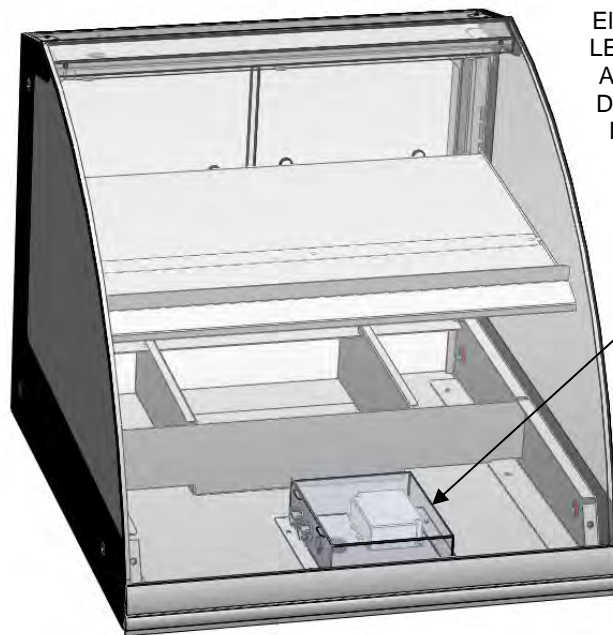

Electrical Box and LED Driver Shown After Removal of Deck Pan (Model DG2422.5171)

Electrical Box and LED Driver Shown After Removal of Deck Pan (Model DG2422.5171)

REAR STORAGE BINS / MODEL DG2422 (STANDARD MODEL ONLY) HINGED DOOR OPENING

Model DG2422.5171 Rear Storage Bins

- Only Model DG2422.5171 has rear storage bins for bags, tongs, napkins, etc.
- Illustration at right shows general layout.
- See **GENERAL CLEANING [TO BE PERFORMED BY STORE PERSONNEL]** section for cleaning specifics.

Model DG2422R (Standard Model Only) Door opens via hinge at case rear, left side. Knob is at case rear, right side.

- Door is able to be locked with key-driven latch.
- Turn latch and door can be opened with knob.
- See illustrations below.
- **Note:** See previous page for specifics on **Model DG2422.5171 and Model DG3622 Sliding Door Units.**

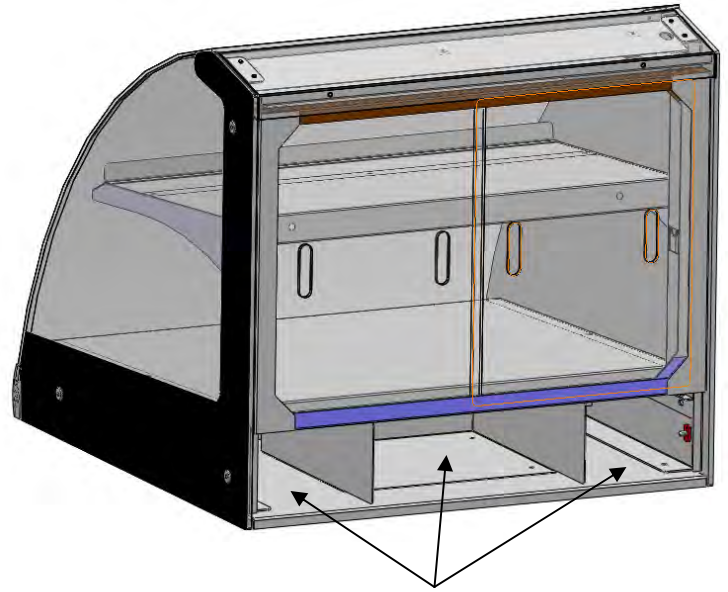

Rear Storage Bins
(Model DG2422.5171 Only)

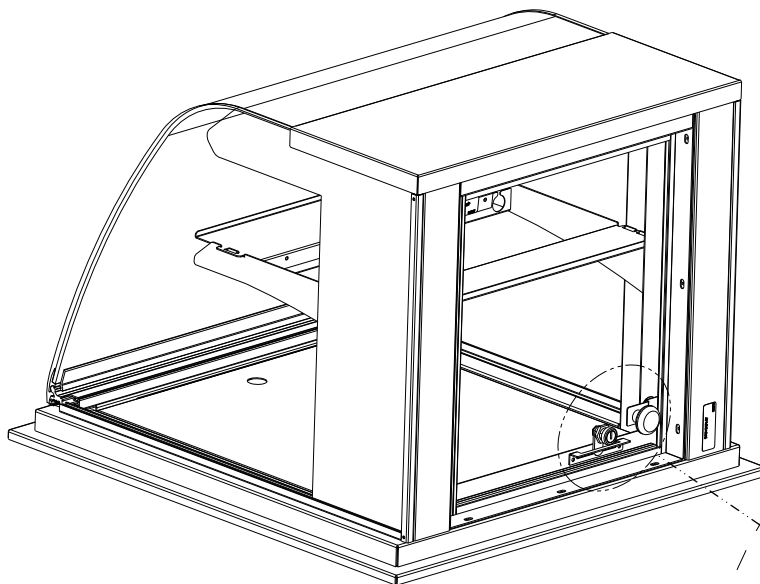

Model DG2422
Shown Above

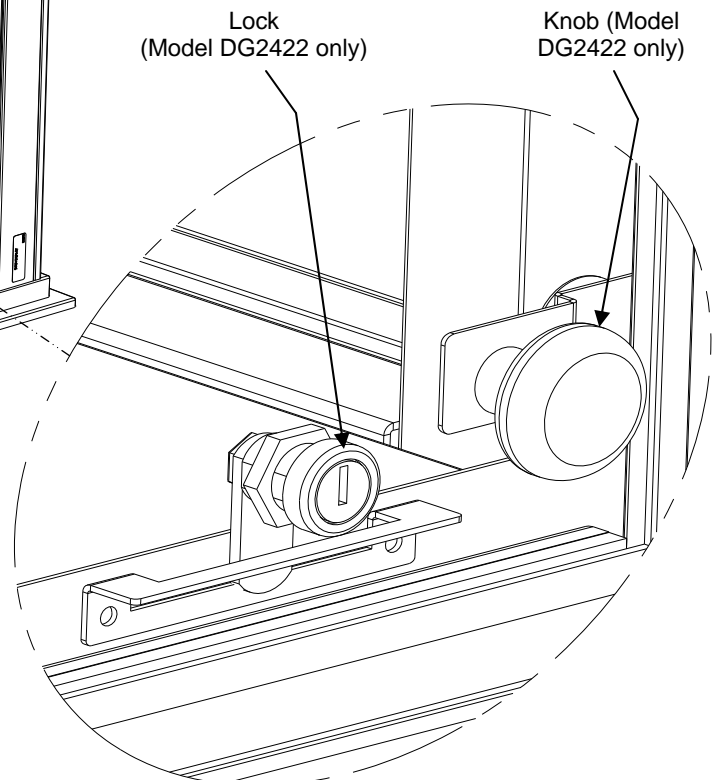

GENERAL CLEANING [TO BE PERFORMED BY STORE PERSONNEL]



Cleaning	Daily	Weekly	Task
Clean Case Exterior	X		Clean outside surface of front curved glass (and rear glass doors) with a household or commercial glass cleaner.
Clean Case Interior	X		Glass shelves may be cleaned with a household or commercial glass cleaner.
	X		Metal shelves may be cleaned with mild soap and water solution and soft cloth. For stubborn stains shelves may be removed and submersed in hot, soapy water and cleaned with soft bristled brush.
		X	Rear storage bins may be cleaned with a mild soap and water solution and soft cloth.
		X	Clean deck and with mild soap and water solution and soft cloth. For stubborn stains, use Comet or Ajax scouring powder. Rinse after cleaning. Dry thoroughly.
		X	Remove sliding rear doors and clean door track with a household or commercial cleaner and sponge (or soft cloth).

TROUBLESHOOTING



Product is Drying Out	Check the relative humidity in the store.
Case Lights Not Working (Standard Fluorescents)	Check that light switch is turned on.
	Check bulbs for proper installation and connection.
	Check for burned out bulbs.
	Clean dirt and dust from the bulbs to prevent flickering.
	<u>Trained Service Providers Only</u> : Check that power is properly supplied to case.
Case Lights Not Working (LED Lights)	Check that light switch is in the <i>on</i> position.
	Check that ALL of the light cords and plugs are properly connected. See STANDARD FLUORESCENT LIGHT FIXTURES / LED LIGHT FIXTURES section in manual for illustration.
	<u>Trained Service Providers Only</u> : Check voltage at LED drivers. If voltage is entering but not exiting, LED driver may be faulty.

Serial Label Location & Information Listed / Technical Information & Service

- Serial labels are located near the electrical access on your case.
- Serial labels contain electrical, temperature & refrigeration information, as well as regulatory standards to which the case conforms.
- For additional technical information and service, see the *TECHNICAL SERVICE* page in this manual for instructions on contacting Structural Concepts' Technical Service Department.
- See images below for samples of both refrigerated and non-refrigerated serial labels.

 <p>888 E. Porter Rd · Muskegon, MI 49441</p>		 <p>MODEL HV74RSS SCROLL SERIAL NO.</p>	
<p>FOR PARTS AND SERVICE CALL 1-800-433-9489</p>			
 <p>3048256</p>		<p>ELECTRICAL RATING</p>	<p>120/1/60 24A</p>
<p>CONFORMS TO UL STD 471</p>		<p>REFRIGERANT</p>	<p>R404A AMOUNT ?? OZ</p>
<p>CONFORMS TO NSF STD 7</p>		<p>DESIGN PRESSURE</p>	<p>HIGH 450 LOW 200</p>
<p>CERTIFIED TO CAN/CSA STD C22.2 NO 120</p>		<p>MINIMUM CIRCUIT</p>	<p>30A</p>
		<p>MAXIMUM OVERCURRENT</p>	<p>30A</p>
<p>Super Heat Temp</p>		<p>8-10°F</p>	
<p>BTUH Requirements</p>		<p>9,738 BTUH @ 20° F SST</p>	
<p>Defrost</p>		<p>6 defrosts per day, 45° F termination, 45 min. failsafe</p>	

----- Sample Serial Label For Refrigerated Case -----

 <p>888 E. Porter Rd · Muskegon, MI 49441</p>		 <p>PC5682 txtRemote</p>	
 <p>3048256</p>		<p>txtSerialNumber</p>	
<p>CONFORMS TO UL STD 65</p>		<p>120 VOLTS 60 HZ SINGLE PHASE 1.84AMP</p>	
<p>CERTIFIED TO CAN/CSA STD C22.2 NO 120</p>		<p>FOR PARTS OR SERVICE CALL STRUCTURAL CONCEPTS AT 1-800-433-9489</p>	
		<p>SAMPLE ONLY</p>	

----- Sample Serial Label For Non-Refrigerated Case -----

STRUCTURAL CONCEPTS CORPORATION TECHNICAL SERVICE
PHONE NUMBER: 1.800.433.9489 or For Your Master Service Agent See
WWW.STRUCTURALCONCEPTS.COM/Contact/Master_Service_Agents.asp

WARRANTY INFORMATION

(Note: Standard Limited Warranty can be found at www.Structuralconcepts.com)

All sales by Structural Concepts Corporation (SCC) are subject to the following limited warranty. "Goods" refers to the product or products being sold by SCC.

Warranty Scope: Warranty is for equipment sold in the United States, Canada, Mexico and Puerto Rico. Equipment sold elsewhere may carry modified warranty.

Warranty; Remedies; Limitations. SCC warrants that if any Goods are found by an authorized representative of SCC not to be of good material or workmanship within one year of the date of shipments SCC will, at its option after inspection by an authorized representative, replace any defective Good or pay the reasonable cost of replacement for any such defective Goods, provided that written notice of the defect is given to SCC within 30 days of the appearance of such defect. If notice is not given within such period, any claim for breach of warranty shall be conclusively deemed to have been waived and SCC shall not be liable under this warranty. If SCC is unable to repair or replace the defective Goods, SCC shall issue a credit to the Purchaser for all or part of the purchase price, as SCC shall determine. The replacement or payment in the manner described above shall be the sole and exclusive remedy of Purchaser for a breach of this warranty. If any Goods are defective or fail to conform to this warranty, SCC will furnish instructions for their disposition. No Goods shall be returned to SCC without its prior consent.

SCC's liability for any defect in the Goods shall not exceed the purchase price of the Goods. SCC SHALL HAVE NO LIABILITY TO PURCHASE FOR CONSEQUENTIAL DAMAGES OF ANY KIND WHATSOEVER, INCLUDING, BUT NOT LIMITED TO, PERSONAL INJURY, PROPERTY DAMAGE, LOST PROFITS, OR OTHER ECONOMIC INJURY DUE TO ANY DEFECT IN THE GOODS OR ANY BREACH OF SCC. SCC SHALL NOT BE LIABLE TO THE PURCHASER IN TORT FOR ANY NEGLIGENT DESIGN OR MANUFACTURE OF THE GOODS, OR FOR THE OMISSION OF ANY WARNING THEREFROM.

SCC shall have no obligation or liability under this warranty for claims arising from any other party's (including Purchaser's) negligence or misuse of the Goods or environmental conditions. This warranty does not apply to any claim or damage arising for or cause by improper storage, handling, installation, maintenance, or from fire, flood, accidents, structural defects, building settlement or movement, acts of God, or other causes beyond SCC's control.

Except as expressly stated herein, SCC makes no warranty, express, implied, statutory or otherwise as to any parts or goods not manufactured by SCC. SCC shall warrant such parts or Goods only (I) against such defects, (II) for such periods of time, and (III) with such remedies, as are expressly warranted by the manufacturer of such parts of Goods. Notwithstanding the foregoing, any warranty with respect to such parts of Goods and any remedies available as a result of a breach thereof shall be subject to all of the procedures, limitations, and exclusions set forth herein.

THE WARRANTIES HEREIN ARE IN LIEU OF ALL WARRANTIES, EXPRESS, IMPLIED, STATUTORY, OR OTHERWISE. IN PARTICULAR, SCC MAKES NO WARRANTY OF MERCHANTABILITY OR FITNESS FOR A PARTICULAR PURPOSE.

No representative, agent or dealer of SCC has authority to modify, expand, or extend this Warranty, to waive any of the limitations or exclusions, or to make any different or additional warranties with respect to Goods.

Period of Limitations. No claim, suit or other proceeding may be brought by Purchaser for any breach of the foregoing warranty or this Agreement by SCC or in any way arising out of this Agreement or relating to the Goods after one year from the date of the breach. In the interpretation of this limitation on action for a breach by SCC, it is expressly agreed that there are no warranties of future performance of the goods that would extend that period of limitation herein contained for bringing an action.

Indemnifications. Purchaser agrees to indemnify, hold harmless, and defend SCC if so requested, from any and all liabilities, as defined herein, suffered, or incurred by SCC as a result of, or in connection with, any act, omission, or use of the Goods by Purchaser, its employees or customers, or any breach of this Agreement by Purchaser. Liabilities shall include all costs, claims, damages, judgments, and expenses (including reasonable attorney fees and costs).

Remedies of SCC. SCC's rights and remedies shall be cumulative and may be exercised from time to time. In a proceeding or action relating to the breach of this Agreement by Purchaser, Purchaser shall reimburse SCC for reasonable costs and attorney's fees incurred by SCC. No waiver by SCC of any breach of Purchaser shall be effective unless in writing nor operate as a waiver of any other breach of the same term thereafter. SCC shall not lose any right because it has not exercised it in the past.

Applicable Law. This Agreement is made in Michigan and shall be governed by and interpreted according to Michigan law. Any lawsuit arising out of this Agreement or the Goods may be handled by a federal or state court whose district includes Muskegon County, Michigan, and Purchaser consents that such court shall have personal jurisdiction over Purchaser.

Miscellaneous. If any provision of this Agreement is found to be invalid or unenforceable under any law, the provision shall be ineffective to that extent and for the duration of the illegality, but the remaining provisions shall be unaffected. Purchaser shall not assign any of its rights nor delegate any of its obligations under this Agreement without prior written of SCC. This Agreement shall be binding upon and inure to the benefit of SCC and Purchaser and each of their legal representatives, successors and assigns.

SCC warrants its products to be free of defects in materials and workmanship under normal use and service for a period of one (1) year from the date of delivery.

This warranty is extended only to the original purchaser for use of the Goods. It does not cover normal wear parts such as plastic tongs, tong holders, tong cables, bag holders, or acrylic dividers.

General Conditions. All service labor and/or parts charges are subject to approval by SCC. Contact the Customer Service Department in writing or call 231-798-8888.

All claims must contain the following information: (1) model & serial code number of equipment; (2) the date and place of installation; (3) the name and address of the agency which performed the installation; (4) the date of the equipment failure; and (5) a complete description of the equipment failure and all circumstances relating to that failure.

Once the claim has been determined to be a true warranty claim by SCC's Customer Service Department, the following procedure will be taken: (1) replacement parts will be sent at no charge from SCC on a freight prepaid basis; (2) reimbursement for service labor will be paid if the following conditions have been met— (a) prior approval of service agency was awarded from the Customer Service Department; and (b) an itemized statement of all labor charges incurred is received by the Customer Service Department. The cost of the service labor reimbursement will be based on straight time rates and reasonable time for the repair of the defect.

If problems occur with any compressor, notify SCC's Customer Service Department immediately. Any attempt to repair or alter the unit without prior consent from the Customer Service Department will render any warranty claim null and void. This warranty and protection plan does not apply to any condensing unit or any part thereof which has been subject to accident, negligence, misuse, or abuse, or which has not been operated in accordance with the manufacturer's recommendations or if the serial number of the unit has been altered, defaced, or removed.

Limit of Liability. The limit of liability of SCC toward the exchange cost of the original condensing unit, F.O.B. SCC, Norton Shores, MI, of each motor-compressor assembly replaced during the warranty shall not exceed manufacturer's current established wholesaler's exchange price and in no case shall the labor of removing or replacing the motor-compressor or parts thereof be the responsibility of SCC.