

ENCORE[®]
SERIES

INSTALLATION & OPERATING MANUAL

PN 99439

SELF-SERVICE BAGEL MERCHANDISER

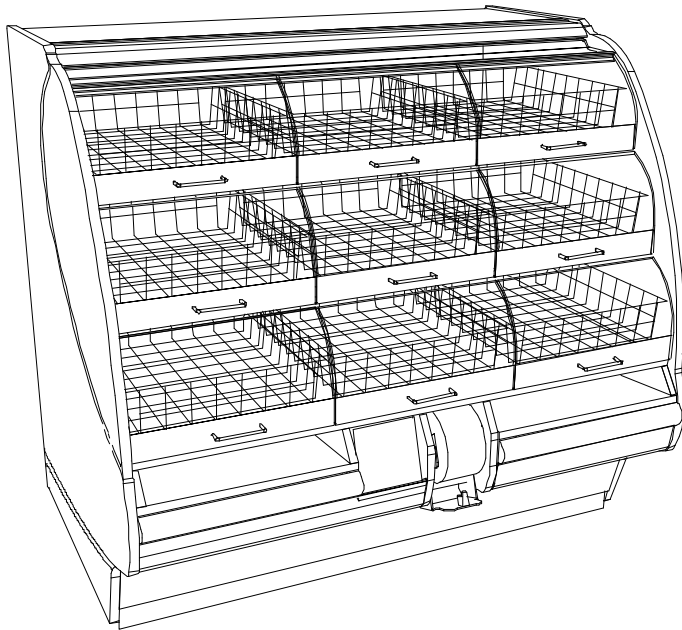

**Standard HVB Model
With Angled Front**

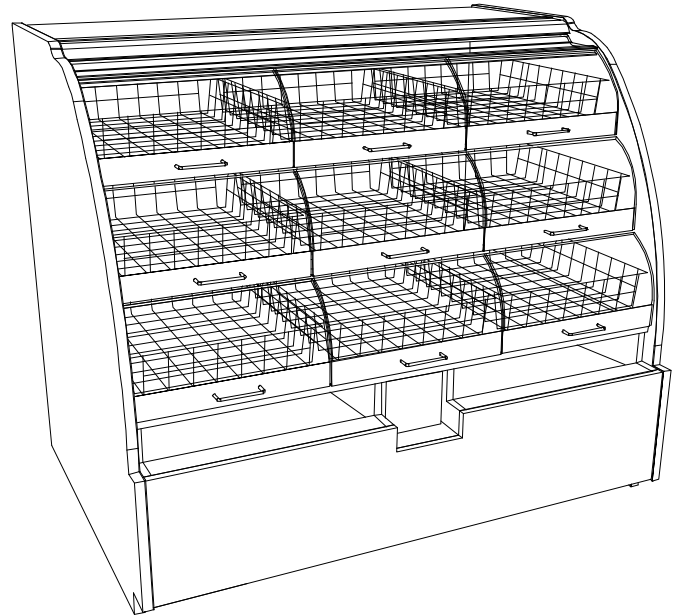

**Standard HVB Model
With Straight Front**

Model HVB38SS	38" L * x 40" D x 50 1/4" H
Model HVB56SS	56" L * x 40" D x 50 1/4" H
Model HVB74SS	74" L * x 40" D x 50 1/4" H

**Without 7/8" end panels.*



888 E. Porter Road · Muskegon, MI 49441 Phone: 231.798.8888 Fax: 231.798.4960 www.structuralconcepts.com

TABLE OF CONTENTS

OVERVIEW AND WARNINGS	3
INSTALLATION	4
POSITIONING AND ALIGNING UNITS	5
ADJUSTING LEVELERS	6
ADJOINING UNITS	7
SET UP	8
OPERATION	9
MAINTENANCE FUNDAMENTALS	10-11
SERIAL LABEL & LOCATION / TECHNICAL INFORMATION / ADD' INFORMATION	12
TROUBLESHOOTING	13
CLEANING SCHEDULE	14
TECHNICAL SERVICE CONTACT INFORMATION & WARRANTY INFORMATION	15

OVERVIEW

- The Structural Concepts Encore service non-refrigerated cases are designed to merchandise unpackaged bakery products at ambient temperatures.
- These cases should be installed and operated according to the following instructions to insure proper performance.
- This unit is designed for the display of products in ambient store conditions where temperatures and humidity are maintained at a maximum of 24° C/ 75° F and 55% relative humidity.



WARNING
Risk of Electric Shock.
Disconnect Power Before Servicing Unit



CAUTION
Lamps have been treated to resist breakage and must be replaced with similarly treated lamps.

INSTALLATION

1. Remove Case From Skid

- To prevent damage, support case while sliding it toward edge of skid.
- When case is at edge of skid, carefully lower to floor (so two levelers rest on floor).
- Carefully slide skid out from under case.
- After removal of case from skid, place into position.
- *Note: Illustration below reflects general outline of sample case and does not reflect any particular model or options).*

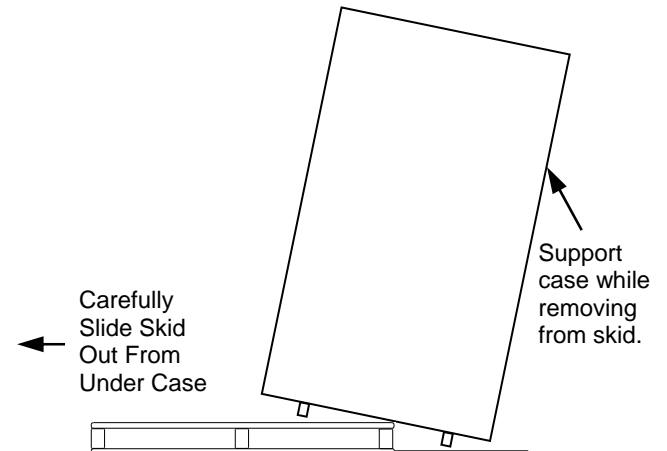

2. Remove Shipping Braces (If Present)

- Remove screws from base, shelves and top of upright. Discard shipping braces.
- Shipping braces may be attached in one of two methods. See illustration at lower-right.

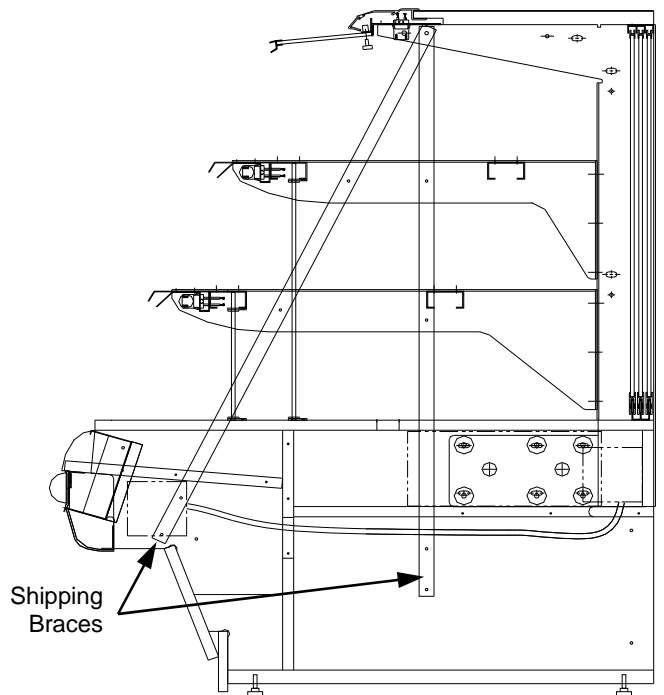

POSITIONING AND ALIGNING UNITS

Positioning and Aligning Units

- Place case into proper position.
- Align multiple units carefully in areas A, B, and C (shown in illustration below).

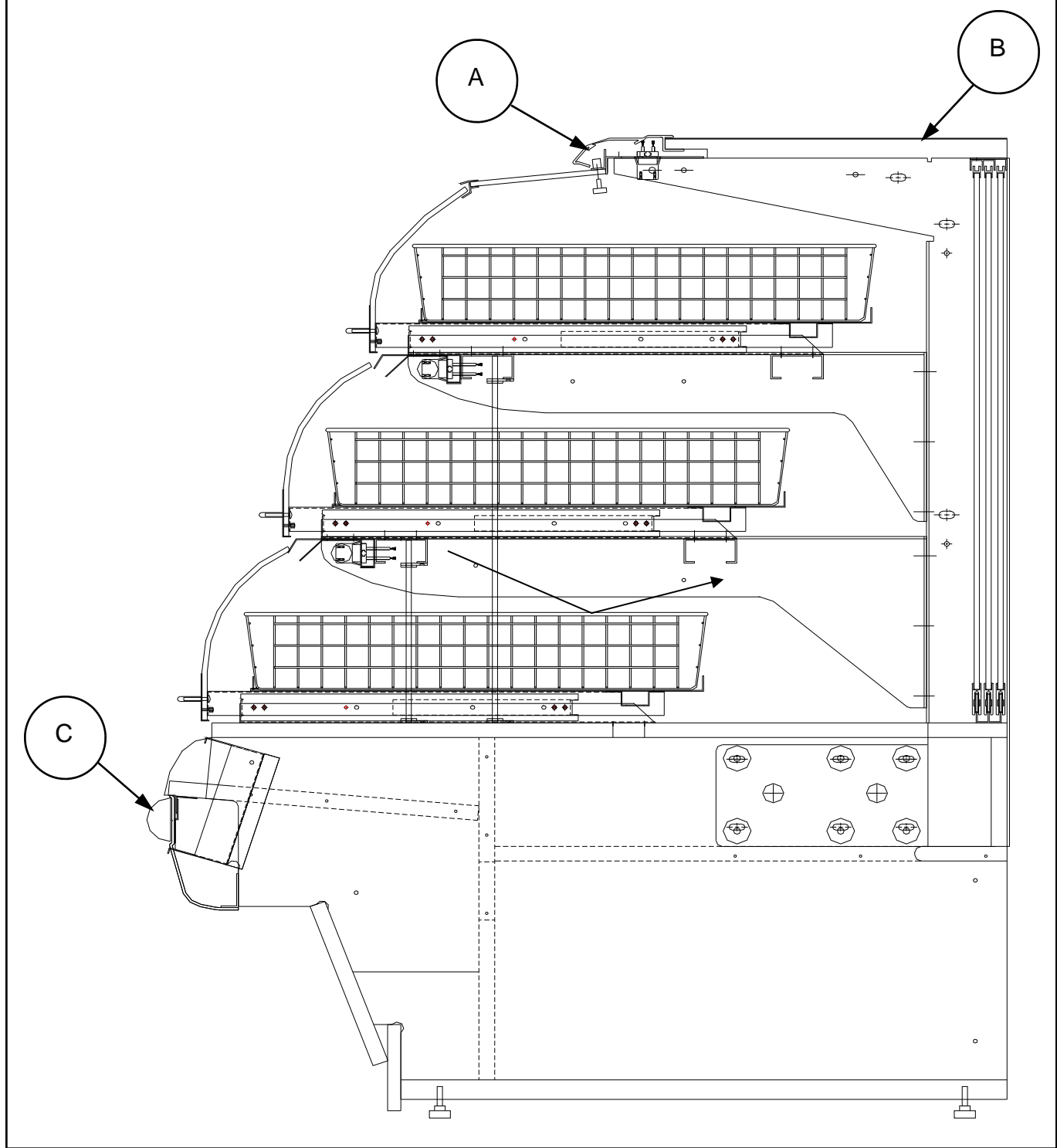

ADJUSTING LEVELERS

Adjust Levelers

- Before proceeding, make certain that the case is in proper position and, if required, align with adjoining case(s).
- After case is in proper position, adjust case so it is level and plumb (see illustration at right).
- You may need to remove front and/or rear Toe-Kick to access levelers.
- Use adjustable wrench to adjust leveler.
- Depending upon case weight it may be necessary to use a Pry Bar to accomplish this task.
- Do not use Pry Bar on Toe-Kick as it may buckle.
- Do not use Pry Bar on End Panel as it may chip.
- Use Pry Bar ONLY on Base Frame to avoid damaging case.
- See illustration below (may not exactly reflect every feature or option of your particular case).

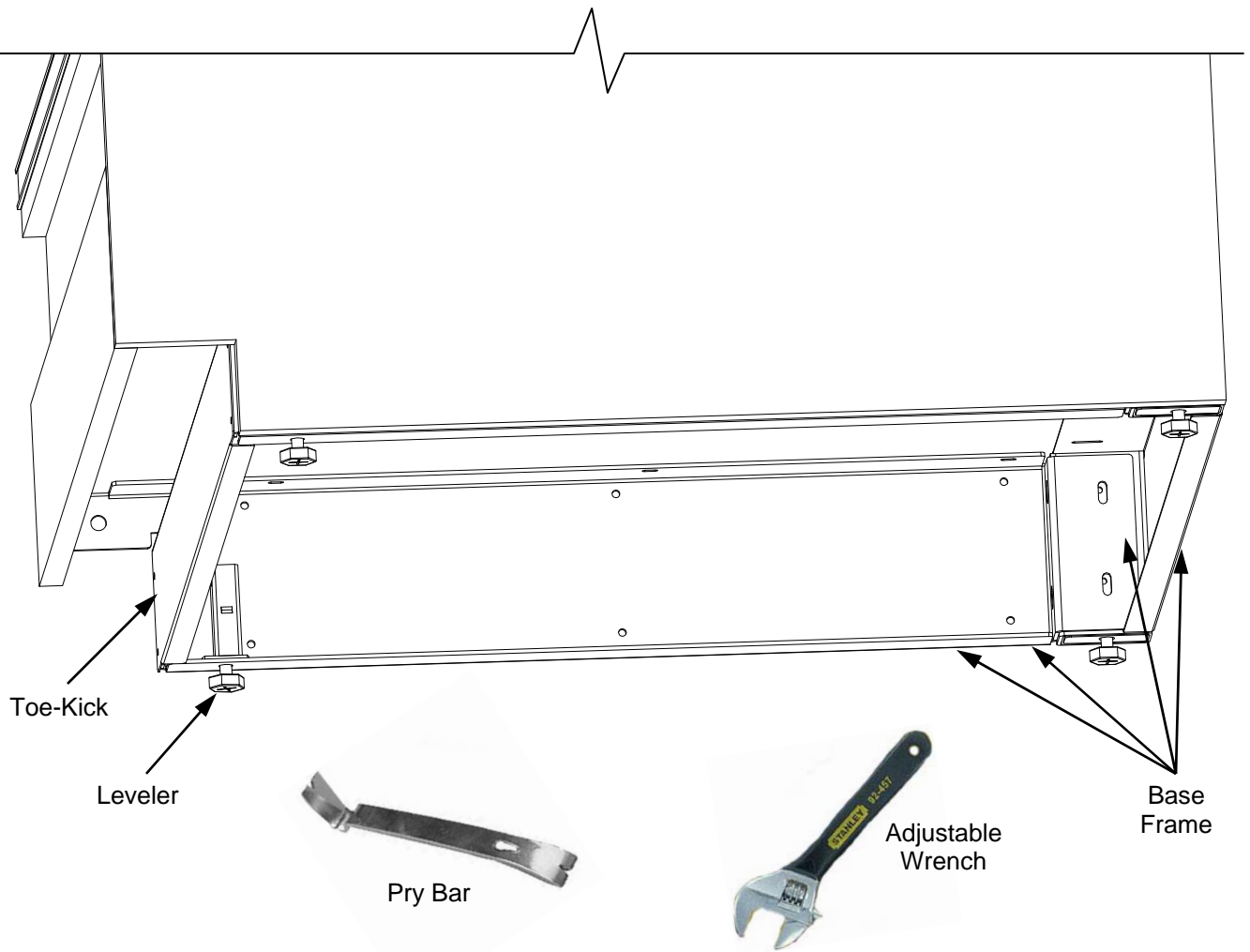

ADJOINING UNITS

Adjoined Units

Units which are aligned as one, can be fastened together at holes indicated.

Note: *Illustration at right may not reflect every feature / option of your particular case.*

- Access bolt holes are at 7 locations.
 - Use Hex Head 1/4-20 X .75 bolt with washers at hole location #1 ONLY.
 - Use 1/4-20 x .75" screws with washers for locations 2 thru 4
 - Use 1/4-20 X 2.25 screws with washers at hole location 5 thru 7.
 - Remove front panel to access bolt hole #7.

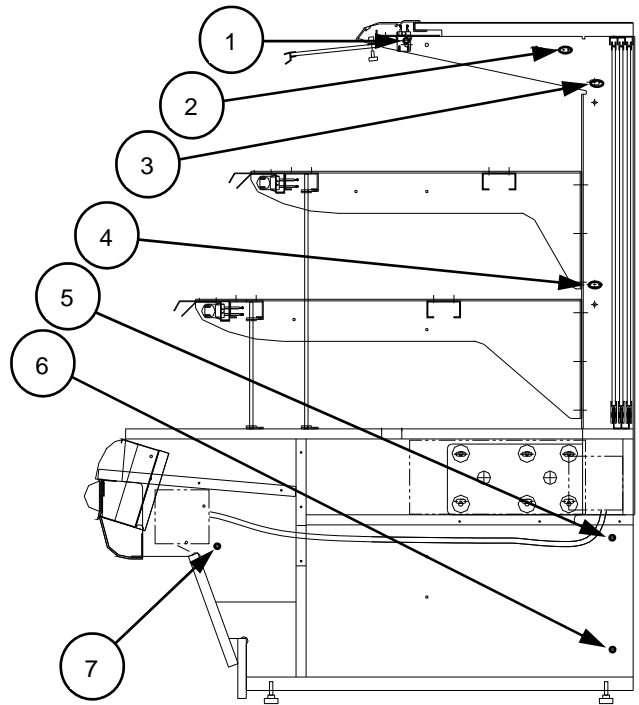

SET UP

For your safety, equipment is furnished with a properly grounded cord connector. Do not attempt to defeat the grounded connector.

Electrical Access and Connections

Merchandiser Start-Up

With Power Cord

- Do not use an extension cord with this appliance.
- Do not operate this equipment with a damaged cord, plug or outlet.
- Insure the power switch is off.
- Plug cord into a certified 120V electrical outlet with ground.

Without Power Cord

- Electrical leads are provided inside the base exiting the ballast box.
- Front or rear electrical access is provided at customer request.
 - See maintenance fundamentals for ballast access to service.

Illustrations may not depict an exact representation of the unit being installed.

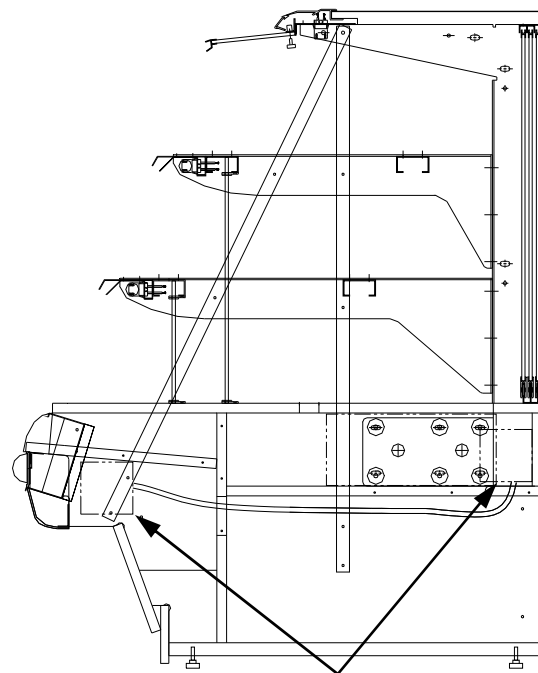

Ballast Box Locations

OPERATION

Turn Lights On

- Models with a switch, the switch is located inside the right rear base storage area.
- Turn on the lights. All of the lights should come on at the same time. First time lighting may require a short warm up period for the bulbs. Slightly dim or a flickering of new bulbs is normal. If lights do not turn on, check all of the raceway plugs.

Pull Out Tray Extension.

- Pull out trays are designed to travel to a distance of 16" and remain extended.
- Trays are self-closing and set in motion by a gentle nudge inward.
- *Note: do not use air pressure to remove crumbs and debris from support decks.*
 - *Activity can cause improper action of drawer slides by lodging fragments into the slide mechanisms.*
- See maintenance fundamentals for cleaning.

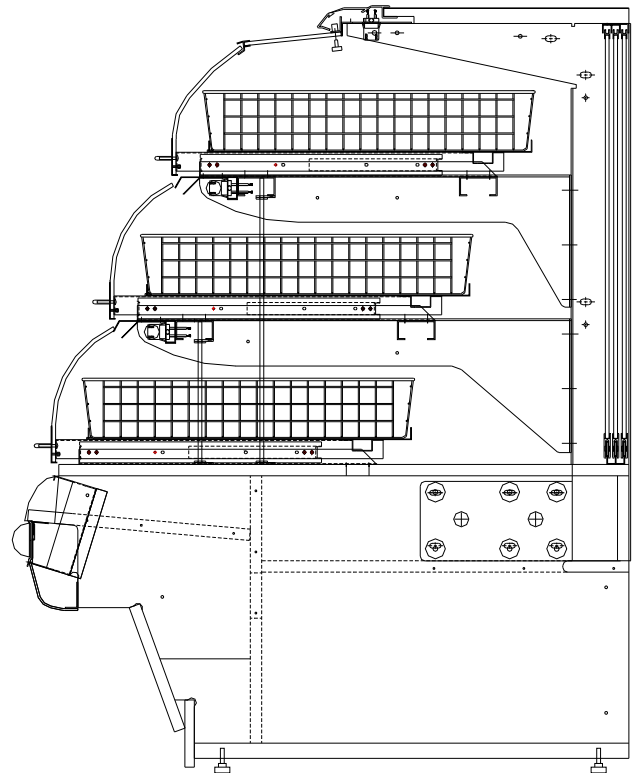

Removing the Rear Doors

- Move the rear doors toward the center of the case.
- Individually lift each door up toward the top of the case and pivot the bottom of the door out.

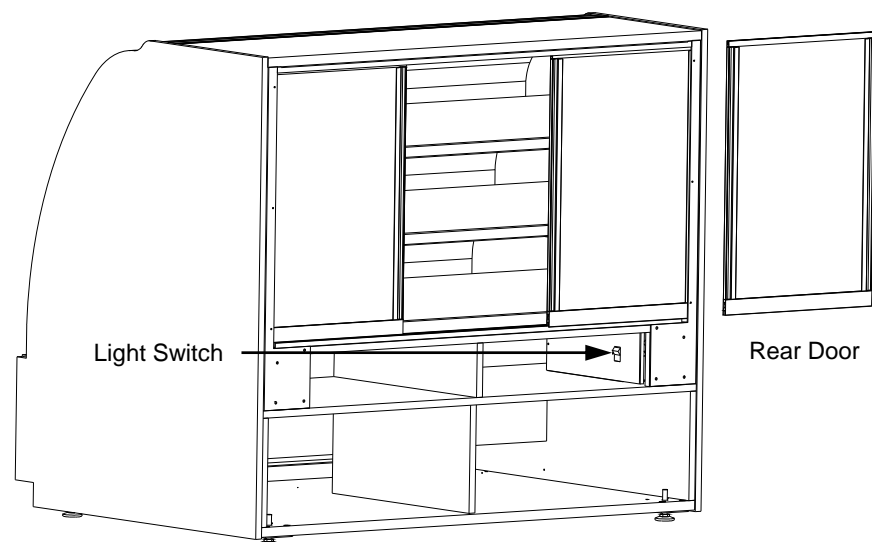

Removing the Rear Doors

- Move the rear doors toward the center of the case.
- Individually lift each door up toward the top of the case and pivot the bottom of the door out.

Light Fixtures

Light fixtures can be located on the underside of each shelf assembly and at the top inside of case.

Removal of lamp:

- Rotate lamp (1/4 turn) so that pins are aligned in slots and remove bulb.

Installation of lamp:

- Align pins with slot.
- Insert pins into socket and rotate 1/4 turn to secure pin contacts in socket.

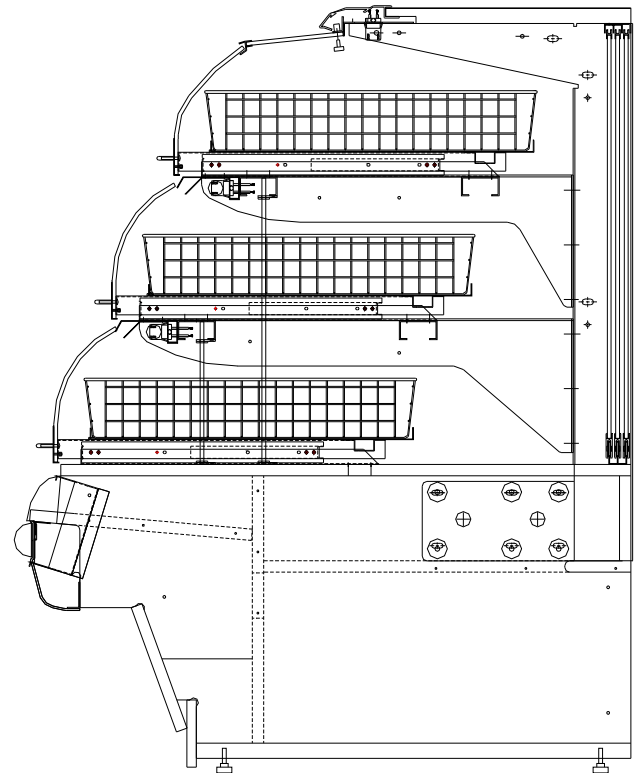

Pull Out Tray Removal

- Trays can be removed for cleaning or adjustments
- *Note: do not use air pressure to remove crumbs and debris from support decks.*
 - *Activity can cause improper action of drawer slides by lodging fragments into the slide mechanisms.*
- Extend the tray approximately half the total travel.
- The tray base is secured to the units deck at the rear of the base.

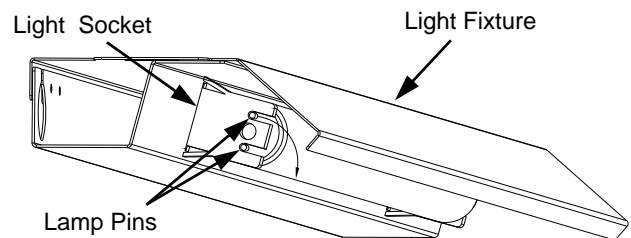

Tray Disassembly

- *Do Not Remove rivets.*
- Extend tray to maximum travel.
- Remove screws that secure drawer slides to base on both sides.

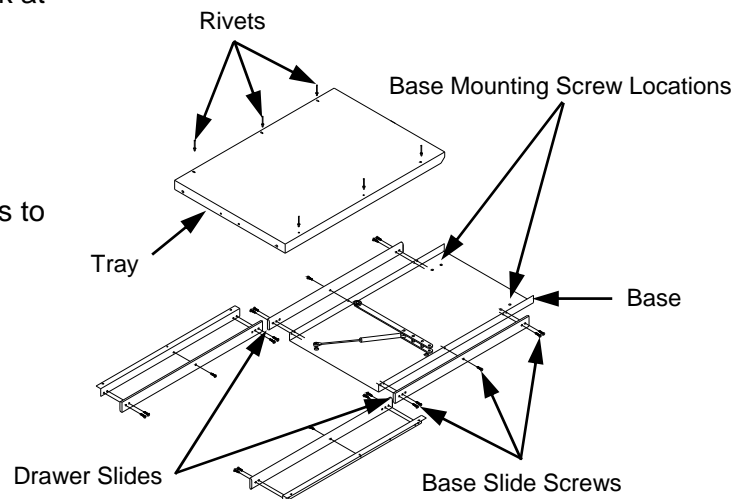

Front Panel Removal

- Loosen screws located on the underside of the front panel.
- Pulling the lower edge out and letting the panel drop down will separate it from the alignment bracket.

Warning, disconnect power before performing maintenance and service to unit.

Light Ballast Access/Removal

Assembly or disassembly and servicing to be accomplished by licensed electrical contractor.

- The light ballast is located inside the ballast box.
 - Remove ballast cover panel (two screws).
 - Release quick disconnect from wire harness.
 - Remove two nuts from both ends of ballast mounting flanges.

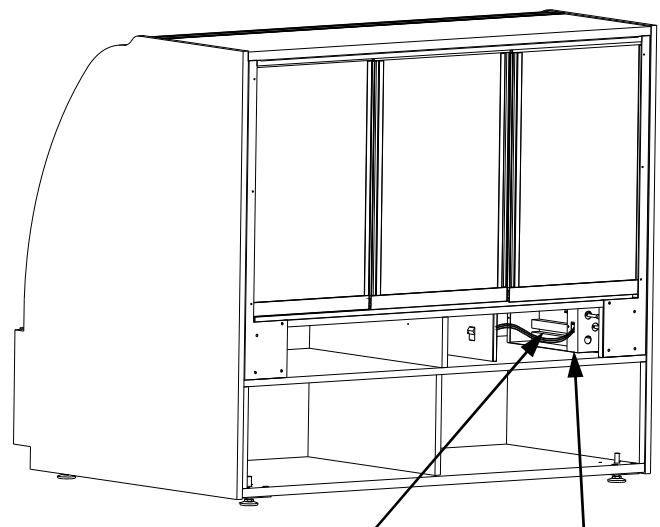
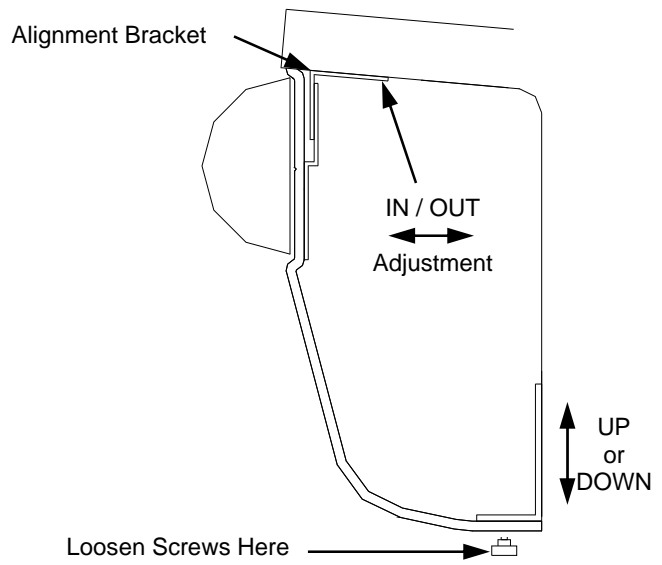

Light Ballast (Note: Ballast Box Shown Transparent For Illustrative Purposes Only)

Ballast Box

Serial Label Location & Information Listed / Technical Information & Service

- Serial labels are located near the electrical access on your case.
- Serial labels contain electrical, temperature & refrigeration information, as well as regulatory standards to which the case conforms.
- For additional technical information and service, see the *TECHNICAL SERVICE* page in this manual for instructions on contacting Structural Concepts' Technical Service Department.
- See images below for samples of both refrigerated and non-refrigerated serial labels.



888 E. Porter Rd · Muskegon, MI 49441

ENCORE[®] MODEL HV74RSS SCROLL
SERIES SERIAL NO.

FOR PARTS AND SERVICE
CALL 1-800-433-9489



3048256
CONFORMS TO UL STD 471
CONFORMS TO NSF STD 7
CERTIFIED TO CAN/CSA
STD C22.2 NO 120

ELECTRICAL RATING 120/1/60 24A
REFRIGERANT R404A AMOUNT ?? OZ
DESIGN PRESSURE HIGH 450 LOW 200
MINIMUM CIRCUIT 30A
MAXIMUM OVERCURRENT 30A

SAMPLE ONLY

Super Heat Temp	8-10°F
BTUH Requirements	9,738 BTUH @ 20° F SST
Defrost	6 defrosts per day, 45° F termination, 45 min. failsafe

SAMPLE ONLY

SAMPLE ONLY

----- Sample Serial Label For Refrigerated Case -----



888 E. Porter Rd · Muskegon, MI 49441

Addenda[®] PC5682 txtRemote
txtSerialNumber

120 VOLTS 60 HZ SINGLE PHASE 1.84AMP

FOR PARTS OR SERVICE CALL
STRUCTURAL CONCEPTS
AT
1-800-433-9489



3048256
CONFORMS TO UL STD 65
CERTIFIED TO CAN/CSA
STD C22.2 NO 120

SAMPLE ONLY

N/A

----- Sample Serial Label For Non-Refrigerated Case -----

TROUBLESHOOTING

Product is Drying Out	Check the relative humidity in the store.
Doors Won't Shut Properly	Check the case is aligned, level and plumb.
System is not Operating	Confirm the utility power is on.
	Check the MAIN power switch is on.
	Check the circuit breaker box for tripped circuits.
	If used, check the unit is properly plugged in.
Case Lights Not Working	Be sure ALL lights are plugged in or receptacles capped.
	Check bulb for proper installation and connection.
	Check for burned out bulb.
	Clean dirt and dust from the bulbs to prevent flickering.
	After performing all other checkpoints and lights are still not working Check for faulty ballast , this should be performed by a certified electrician.

CLEANING SCHEDULE (MODEL HVB38SS, HVB56SS, HVB74SS)

Cleaning	Daily	Weekly	Monthly	Task
Clean Case Exterior	X			The acrylic must be cleaned with a mild soap and water solution and a soft cloth (Never use a household cleaner on acrylic) .
Clean Case Interior	X			Clean glass shelves and mirrors with a household or commercial glass cleaner. The deck can be cleaned with a warm soap and water solution.
		X		Remove the trays and clean with soap and water.
		X		Remove rear doors and clean with a household or commercial cleaner (Service Cases Only).

STRUCTURAL CONCEPTS CORPORATION TECHNICAL SERVICE
PHONE NUMBER: 1.800.433.9489 or For Your Master Service Agent See
WWW.STRUCTURALCONCEPTS.COM/Contact/Master_Service_Agents.asp

WARRANTY INFORMATION

(Note: Standard Limited Warranty can be found at www.Structuralconcepts.com)

All sales by Structural Concepts Corporation (SCC) are subject to the following limited warranty. "Goods" refers to the product or products being sold by SCC.

Warranty Scope: Warranty is for equipment sold in the United States, Canada, Mexico and Puerto Rico. Equipment sold elsewhere may carry modified warranty.

Warranty; Remedies; Limitations. SCC warrants that if any Goods are found by an authorized representative of SCC not to be of good material or workmanship within one year of the date of shipments SCC will, at its option after inspection by an authorized representative, replace any defective Good or pay the reasonable cost of replacement for any such defective Goods, provided that written notice of the defect is given to SCC within 30 days of the appearance of such defect. If notice is not given within such period, any claim for breach of warranty shall be conclusively deemed to have been waived and SCC shall not be liable under this warranty. If SCC is unable to repair or replace the defective Goods, SCC shall issue a credit to the Purchaser for all or part of the purchase price, as SCC shall determine. The replacement or payment in the manner described above shall be the sole and exclusive remedy of Purchaser for a breach of this warranty. If any Goods are defective or fail to conform to this warranty, SCC will furnish instructions for their disposition. No Goods shall be returned to SCC without its prior consent.

SCC's liability for any defect in the Goods shall not exceed the purchase price of the Goods. SCC SHALL HAVE NO LIABILITY TO PURCHASE FOR CONSEQUENTIAL DAMAGES OF ANY KIND WHATSOEVER, INCLUDING, BUT NOT LIMITED TO, PERSONAL INJURY, PROPERTY DAMAGE, LOST PROFITS, OR OTHER ECONOMIC INJURY DUE TO ANY DEFECT IN THE GOODS OR ANY BREACH OF SCC. SCC SHALL NOT BE LIABLE TO THE PURCHASER IN TORT FOR ANY NEGLIGENT DESIGN OR MANUFACTURE OF THE GOODS, OR FOR THE OMISSION OF ANY WARNING THEREFROM.

SCC shall have no obligation or liability under this warranty for claims arising from any other party's (including Purchaser's) negligence or misuse of the Goods or environmental conditions. This warranty does not apply to any claim or damage arising for or cause by improper storage, handling, installation, maintenance, or from fire, flood, accidents, structural defects, building settlement or movement, acts of God, or other causes beyond SCC's control.

Except as expressly stated herein, SCC makes no warranty, express, implied, statutory or otherwise as to any parts or goods not manufactured by SCC. SCC shall warrant such parts or Goods only (I) against such defects, (II) for such periods of time, and (III) with such remedies, as are expressly warranted by the manufacturer of such parts of Goods. Notwithstanding the foregoing, any warranty with respect to such parts of Goods and any remedies available as a result of a breach thereof shall be subject to all of the procedures, limitations, and exclusions set forth herein.

THE WARRANTIES HEREIN ARE IN LIEU OF ALL WARRANTIES, EXPRESS, IMPLIED, STATUTORY, OR OTHERWISE. IN PARTICULAR, SCC MAKES NO WARRANTY OF MERCHANTABILITY OR FITNESS FOR A PARTICULAR PURPOSE.

No representative, agent or dealer of SCC has authority to modify, expand, or extend this Warranty, to waive any of the limitations or exclusions, or to make any different or additional warranties with respect to Goods.

Period of Limitations. No claim, suit or other proceeding may be brought by Purchaser for any breach of the foregoing warranty or this Agreement by SCC or in any way arising out of this Agreement or relating to the Goods after one year from the date of the breach. In the interpretation of this limitation on action for a breach by SCC, it is expressly agreed that there are no warranties of future performance of the goods that would extend that period of limitation herein contained for bringing an action.

Indemnifications. Purchaser agrees to indemnify, hold harmless, and defend SCC if so requested, from any and all liabilities, as defined herein, suffered, or incurred by SCC as a result of, or in connection with, any act, omission, or use of the Goods by Purchaser, its employees or customers, or any breach of this Agreement by Purchaser. Liabilities shall include all costs, claims, damages, judgments, and expenses (including reasonable attorney fees and costs).

Remedies of SCC. SCC's rights and remedies shall be cumulative and may be exercised from time to time. In a proceeding or action relating to the breach of this Agreement by Purchaser, Purchaser shall reimburse SCC for reasonable costs and attorney's fees incurred by SCC. No waiver by SCC of any breach of Purchaser shall be effective unless in writing nor operate as a waiver of any other breach of the same term thereafter. SCC shall not lose any right because it has not exercised it in the past.

Applicable Law. This Agreement is made in Michigan and shall be governed by and interpreted according to Michigan law. Any lawsuit arising out of this Agreement or the Goods may be handled by a federal or state court whose district includes Muskegon County, Michigan, and Purchaser consents that such court shall have personal jurisdiction over Purchaser.

Miscellaneous. If any provision of this Agreement is found to be invalid or unenforceable under any law, the provision shall be ineffective to that extent and for the duration of the illegality, but the remaining provisions shall be unaffected. Purchaser shall not assign any of its rights nor delegate any of its obligations under this Agreement without prior written of SCC. This Agreement shall be binding upon and inure to the benefit of SCC and Purchaser and each of their legal representatives, successors and assigns.

SCC warrants its products to be free of defects in materials and workmanship under normal use and service for a period of one (1) year from the date of delivery.

This warranty is extended only to the original purchaser for use of the Goods. It does not cover normal wear parts such as plastic tongs, tong holders, tong cables, bag holders, or acrylic dividers.

General Conditions. All service labor and/or parts charges are subject to approval by SCC. Contact the Customer Service Department in writing or call 231-798-8888.

All claims must contain the following information: (1) model & serial code number of equipment; (2) the date and place of installation; (3) the name and address of the agency which performed the installation; (4) the date of the equipment failure; and (5) a complete description of the equipment failure and all circumstances relating to that failure.

Once the claim has been determined to be a true warranty claim by SCC's Customer Service Department, the following procedure will be taken: (1) replacement parts will be sent at no charge from SCC on a freight prepaid basis; (2) reimbursement for service labor will be paid if the following conditions have been met— (a) prior approval of service agency was awarded from the Customer Service Department; and (b) an itemized statement of all labor charges incurred is received by the Customer Service Department. The cost of the service labor reimbursement will be based on straight time rates and reasonable time for the repair of the defect.

If problems occur with any compressor, notify SCC's Customer Service Department immediately. Any attempt to repair or alter the unit without prior consent from the Customer Service Department will render any warranty claim null and void. This warranty and protection plan does not apply to any condensing unit or any part thereof which has been subject to accident, negligence, misuse, or abuse, or which has not been operated in accordance with the manufacturer's recommendations or if the serial number of the unit has been altered, defaced, or removed.

Limit of Liability. The limit of liability of SCC toward the exchange cost of the original condensing unit, F.O.B. SCC, Norton Shores, MI, of each motor-compressor assembly replaced during the warranty shall not exceed manufacturer's current established wholesaler's exchange price and in no case shall the labor of removing or replacing the motor-compressor or parts thereof be the responsibility of SCC.